

**Model
1-10D/1-10DSMKIII &
1-15D/1-15DSMKIII**

October 2008

FORWARD

Blastrac is pleased that you have selected this Blast Cleaning System for your surface preparation requirements. This environmentally safe, closed-cycle, surface preparation machine has been designed and built for abrasive blast cleaning of horizontal surfaces.

This manual has been prepared to assist the operator and the maintenance personnel in understanding the machine so that it may be operated in the most efficient manner and maintained in the best condition. Therefore, it is necessary that all personnel responsible for the operation and maintenance of the machine read the manual thoroughly. By following the instructions in this manual, this system can be easily and effectively operated, serviced and maintained by personnel assisted by a brief period of familiarization and training from a Blastrac® technician.

Before attempting to operate, service, or maintain the machine, the personnel should thoroughly familiarize themselves with the physical makeup of the machine, be familiar with the major systems of the machine, and have an understanding of its operation.

The operating and maintenance personnel must obey all the warnings and safety precautions posted on the side of the machine and stated throughout this manual. Serious injury to personnel or severe damage to the equipment may result if the warnings and precautions are not followed, or through careless handling of this equipment.

Initial operation and maintenance must be done cautiously. Extreme care should be taken when activating any control devices until the response of the machine and its various components are clearly understood.

If you have any questions or problems in regard to the operation or capabilities of this Blastrac machine, please contact:

Blastrac
13201 North Santa Fe
Oklahoma City, OK 73114
405/478-3440
800/256-3440

or your nearest Service Center.

INTRODUCTION

This manual has been prepared to assist the operator and maintenance personnel in understanding the machine so that it may be operated in the safest and most efficient manner and maintained in the best condition. Therefore, it is necessary that all personnel responsible for the operation and maintenance of the machine read and understand the manual.

Before attempting to operate service or maintain the machine, the personnel should thoroughly familiarize themselves with the physical make-up of the machine. They should be familiar with the major components of the machine and have a general understanding of overall operations.

The operating and maintenance personnel must obey all the warnings and safety precautions posted on the machine and stated throughout this manual. Serious injury to personnel or severe damage to the equipment may result if the warnings and precautions are not followed.

You will be notified of any changes that occur after this manual is printed. We will send you manual revisions that should be inserted in the manual in accordance with instructions that will be forwarded with them.

Receipt of Machine

Examine the shipment carefully for possible damage that might have occurred while in transit. If any damage is noted, notify the transportation carrier immediately and advise Blastrac.



Operating Instructions

**1-10D/1-10DSMKIII
& 1-15D/1-15DSMKIII**

Safety Precautions

Section 1

- 1.1 Safety Instructions
- 1.2 Mechanical
- 1.3 Electrical
- 1.4 Dust collector and Ventilation



Operating Instructions

1-10D/1-10DSMKIII
& 1-15D/1-15DSMKIII

Safety Precautions

1.1 Safety Instructions

Note: All operators and maintenance personnel should read and understand the entire Operating Instructions Manual before attempting to operate or maintain this machine. Pay close attention to all safety instructions, dangers, warnings and cautions.

This Blastrac® Operator's Manual has been specifically prepared for operating and maintenance personnel working with the Model 1-10DMKII, 1-10DSMKIII, 1-15DMKIII, 1-15DSMKIII and 654 Dust Collector shotblasting system(s). The information in this manual is intended to provide an understanding of the equipment and its intended use. A complete understanding of the Operating Instructions Manual will help maximize productivity and minimize the safety risks associated with operating and maintaining this machine.

All operating and maintenance personnel must observe all warnings and precautions that are listed in this manual for the Model 1-10DMKIII, 1-10DSMKIII, 1-15DMKIII, 1-15DSMKIII and 654 Dust Collector. **All safety labels posted on the machine must be followed** as well as the safety program instituted by your individual management.

This Blastrac equipment has been manufactured for specific floor preparation applications. The engineering design of this airless media blast machine incorporates several basic elements. These include the airless media blast wheel, media recycling system and dust collection system. As a result of many years of operating and engineering experience, the features of these machines when used with the proper operating and maintenance procedures enable them to operate in a safe, efficient and trouble-free manner.

A complete understanding of the Operating Instructions Manual will help maximize productivity and minimize the safety risks associated with operating and maintaining this machine. No instructions, written or verbal, can be effective without the use of sound judgment and good work practices in the operation and maintenance of the equipment. Listed below are the practices that should always be observed.



Operating Instructions

1-10D/1-10DSMKIII
& 1-15D/1-15DSMKIII

Safety Precautions

1.1 Cont'd

WARNING!

Breathable silica may be generated by use and maintenance of this equipment. Silica can cause severe and permanent lung damage, cancer, and other serious diseases. Do not breathe the dust. Do not rely on your sight or smell to determine if dust is in the air. Silica may be in the air without a visible dust cloud. If air monitoring equipment for silica is not provided by your employer at your worksite, you **MUST** wear appropriate respiratory protection when operating and maintaining this equipment. Consult your employer about appropriate respiratory protection.

CAUTION

Always keep the abrasive valve control lever in the off/closed position except when the machine is actually blast cleaning. Whenever an irregular, unusual or hazardous performance of the machine occurs, immediately close the abrasive control valve, release the handle mounted traverse control lever to deactivate the travel limit switch and shut off the blast wheel motor. An emergency stop switch is also provided on the front of the control panel that may also be used in the event of an emergency situation.

Before actual shotblasting can begin, the operator should be certain that the machine can clear all obstructions in the work area. Work areas must be dry and clean (no loose debris) before cleaning can begin.

Maintain all guards in place - Blastrac machines are equipped with guards or coverings for parts that may be hazardous.

All personnel in the immediate work area **must wear safety glasses with side shields** whenever the machine is blasting. Protective clothing is also recommended. Long sleeve shirts and safety shoes should be worn and loose clothing should be avoided. The abrasive used in the machine impacts the work surface at high velocity. Any leakage during normal operation can sting personnel in the surrounding area. **The blast head must be sealed to the work surface during operation to prevent abrasive leakage.**



Operating Instructions

1-10D/1-10DSMKIII
& 1-15D/1-15DSMKIII

Safety Precautions

1.2 Mechanical

1. Before performing any type of maintenance on your Blastrac equipment, be sure that all moving parts have completely stopped. The blast wheel, for example, may continue to rotate for a period of time once it has been deactivated.
 - Assure every power source that can produce mechanical movement has been deactivated and locked in the off position.
 - Assure all potential energy sources have been minimized. (Example: Move the machine to level ground before performing any maintenance so machine cannot move by gravitational force.)
 - Assure loose or freely moveable parts of the machine have been secured against accidental movement.
2. All drive guards must be kept in place and in good condition except during maintenance or when repair work is being performed. Once maintenance or repair work is complete, be sure all guards are securely remounted.
3. Safety glasses with side shields should always be worn when working with or near equipment in use. Gloves, when applicable, can be worn for added protection.
4. Loose fitting clothing and gloves should not be worn when working near belts, chains, sprockets, shafts and other moveable components.
5. The blast machine and all areas around the machine should be kept clean. **Loose media in particular can become hazardous for foot traffic. All abrasive leaks should be repaired immediately to help keep the work area free of loose abrasive.**
6. **Any condition(s) that may result in additional damage to the equipment or cause injury to nearby personnel should be repaired immediately.**
7. **Do not attempt to make adjustments to the feed spout or any control cage components while the machine is in motion or the blast wheel is operating. All adjustments must be made when the machine is stationary, the blast wheel is completely stopped and power has been disconnected.**



Operating Instructions

1-10D/1-10DSMKIII
& 1-15D/1-15DSMKIII

Safety Precautions

1.2 Cont'd

8. **Obey all safety labels posted on the machine and all information posted where the machine is being operated.**
9. **Do not operate USF/Blastrac machinery in the rain or when heavy moisture is present. Do not expose the abrasive supply to any type of moisture.** Sticky, tar related and rubber surfaces should be avoided when using Blastrac

1.3 Electrical

machinery. Always drain unused abrasive from the machine and empty the dust collector hopper before transporting the equipment.

1. **CAUTION** - Line terminals may be alive when main switch is in "OFF" position. Disconnect all power before opening enclosure doors.
2. **WARNING** - **DO NOT** operate the equipment with the electrical panel door(s) open.
3. **WARNING** - The opening of any of the branch circuit protective devices may be an indication that a fault current has been interrupted. To ensure continued protection against fire or electric shock, current carrying parts and other components of the combination controller should be examined and replaced if damaged. If burnout of the current element of an overload relay occurs, the complete overload relay must be replaced.
4. Some overload devices in the control panel have an adjustable feature. Assure these settings comply with settings provided for each device in the electrical schematics.
5. Never bypass overcurrent devices provided in this equipment. Never use oversized fuses or bypass any fuses to operate the machinery. Always refer to the electrical



Operating Instructions

**1-10D/1-10DSMKIII
& 1-15D/1-15DSMKIII**

Safety Precautions

drawings provided for the individual machines for proper size and type of overcurrent protection and fuses.

1.3 Cont'd

6. When replacing electrical components, care should be taken to use the exact component that was originally supplied with the machine. These parts are listed in the electrical section of this manual. The electrical components in these systems have been coordinated for optimum protection of personnel and equipment – DO NOT SUBSTITUTE ANY OF THESE COMPONENTS.
5. Never connect or disconnect power cables with voltage present or while under load.
6. **Disconnect all power connections** and observe lock out/ tag out procedures before attempting maintenance or repair of any electrical component.
7. Avoid all contact with rotating motor parts, drives or driven components.
8. Before energizing the equipment, check the condition of all power cables. While extra hard usage Type W cable is provided with this equipment, damage can occur during equipment transit. All cabling should be checked for cuts and worn condition prior to connection to the power source.
9. Cable strain relief devices are provided for all power cabling. Assure that these strain relief devices are secured to the frame of the equipment with the hardware provided prior to energizing the equipment.
10. While safeguards have been provided in this equipment to protect operating personnel and equipment, **ALWAYS CHECK** that the proper power source is connected (voltage, frequency and phase). Check the motors for proper rotation once the power source has been verified. Sustained improper motor rotation can damage machine components.

Your Blastrac Blast Unit and 654 Dust Collector can be operated on 208, 230, 460 and 480 volt, three phase, 60-Hertz power ONLY. Do not attempt to operate this equipment on 50-Hertz power. A 50-Hertz modification kit is available by contacting Blastrac.



Operating Instructions

**1-10D/1-10DSMKIII
& 1-15D/1-15DSMKIII**

Safety Precautions

1.4 Dust Collector and Ventilation

All Blastrac abrasive blast equipment must be properly ventilated to be environmentally effective. This benefits the operator, machine efficiency and **contributes significantly to better wear and less maintenance.**

The dust hoppers of the dust collectors should be kept empty. The importance of checking the dust level during normal working conditions cannot be over-stressed. Doing so allows the blast system to help keep the abrasive as clean as possible, thereby eliminating the greatest cause of wear to the internal components of the machine.

Cleaning the dust hopper at the end of each working day or shift is also very important. Many types of dust (dependent on the surface being cleaned) have the potential to easily ignite when left stored. The hazards of fires and explosions are minimized when the dust is removed as recommended.



Operating Instructions

**1-10D/1-10DSMKIII
& 1-15D/1-15DSMKIII**

Operator Responsibilities

Section 2

2.1 Operator Responsibilities



Operating Instructions

**1-10D/1-10DSMKIII
& 1-15D/1-15DSMKIII**

Operator Responsibilities

2.1 Operator Responsibilities

1. The operator shall provide site electrical power and observe operation ampere maximums according to the following chart.

Site Power Requirements and Blast Motor Maximum Blast Amps				
Parameter	Dust Collector/Blast Unit Combinations			
	6-54/ 1-10DMKIII	6-54/ 1-10DSMKIII	6-54/ 1-15DMKIII	6-54/ 1-15DSMKIII
Minimum Ampere Circuit @ 208/230v	50 AMP	60 AMP	60 AMP	80 AMP
Maximum Ampere Circuit @ 208/230v	100 AMP	100 AMP	100 AMP	100 AMP
Minimum Ampere Circuit @ 460/480v	30 AMP	40 AMP	40 AMP	50 AMP
Maximum Ampere Circuit @ 460/480v	100 AMP	100 AMP	100 AMP	100 AMP
Minimum Generator Size	30 kW	40 kW	40 kW	60 kW
Maximum Blast FLA @ 208/230	25.0 AMP	33.0 AMP	33.0 AMP	49.0 AMP
Maximum Blast FLA @ 460/480	12.5 AMP	16.5 AMP	16.5 AMP	22.5 AMP

2. The operator shall provide personnel who have been trained by a Blastrac Technician for the operation and maintenance of Blastrac equipment.
3. The operator shall provide the necessary blasting media in accordance with the recommendations of a Blastrac technician so that the machine will operate at maximum efficiency.
4. The operator shall be responsible for the observance of all safety precautions expressed in this manual.
5. The operator shall perform all maintenance and basic repair functions as stated and described in this manual.



Operating Instructions

**1-10D/1-10DSMKIII
& 1-15D/1-15DSMKIII**

Operator Responsibilities

2.1 Cont'd

6. The operator shall maintain an inventory of "wear parts" as outlined in this manual.
7. The operator shall dispose of all dust collector refuse.
8. The operator shall provide the following tools and accessories:

Hammer	Screwdrivers
Wrench Set	VOM (meter)
5/16" Allen Wrench	Magnetic Broom
Buckets	



Section 3

- 3.1 Description and Function - General
- 3.2 Blast Units – Abrasive Cleaning Head
- 3.3 Blast Units – Abrasive Control Valve
- 3.4 Blast Units – Rebound Plenum
- 3.5 Blast Units – Separator
- 3.6 Blast Units – Abrasive Seals
- 3.7 Blast Units – Chassis
- 3.8 Blast Units – Control Panels
- 3.9 Dust Collector – General
- 3.10 Dust Collector – Filter Chamber
- 3.11 Dust Collector – Dust Bin
- 3.12 Dust Collector – Blower
- 3.13 Dust Collector – Minihelic Gauge
- 3.14 Dust Collector – Pulse / Pressure System
- 3.15 Dust Collector – Chassis
- 3.16 Dust Collector – Electrical Control Panel
- 3.17 Dust Collector – Ventilation System



Operating Instructions

1-10D/1-10DSMKIII
& 1-15D/1-15DSMKIII

Description and Function

3.1 Description and Function – General

The Blastrac equipment series described herein includes the 1-10DMKIII, 1-10DSMKIII, 1-15DMKIII and the 1-15DSMKIII blast units. Each of these models is used in conjunction with the 6-54 Dust Collector. Each combination comprises a horizontal surface preparation, closed cycle, shotblasting system. The blast unit directs high velocity, metallic abrasive towards the work surface. The impact of each individual particle causes the surface to fracture and become loose. The abrasive and the loose surface particles are then directed upward due to the force of the impact and a strong airflow created by the dust collector. The mixture of shot and contaminants enters the rebound plenum and continues its upward movement until directed into a specially designed chamber called the separator. Inside this chamber, an air wash cleans the abrasive and allows the contaminants to be extracted back to the dust collector. The clean abrasive is then gravity fed to the blast wheel and the process repeats. The blast unit is self-propelled by an adjustable speed DC gearmotor. Under normal blast cleaning conditions, the 6-54 Dust Collector must always be used. The blast units consist of the following elements:

- Abrasive Cleaning Head
- Abrasive Control Valve
- Rebound Plenum
- Separator
- Abrasive Seals
- Chassis
- Control Panel

3.2 Blast Units – Abrasive Cleaning Head

The center of the patented abrasive cleaning head is the power driven, four bladed blast wheel that throws abrasive towards the surface being cleaned. This center fed centrifugal blast wheel propels the abrasive by centrifugal force at a speed of more than 200 mph.

This blast wheel is enclosed in an abrasion resistant housing that is also lined with abrasion resistant liners. These liners are located in areas where the most wear is present. The operator can change them periodically to protect the housing. The blast wheel itself is driven by an electric motor connected to a set of belts and sheaves which are in turn connected to a bearing unit.



Description and Function

3.2 Continued

The blast wheel is equipped with a cast in place impeller for easy maintenance. This impeller pre-accelerates the abrasive to the wheel blades in controlled portions. Abrasive that is gravity fed to the center of the wheel is accelerated in segments and directed through the control cage. The control cage determines where the abrasive is introduced onto the rotating blades of the wheel which in turn determines where the abrasive is being "aimed". The setting of the control cage is very important when setting up the "blast pattern" covered in Section 5.

A digital ammeter provides readout of the current of electric motor that drives the blast wheel. This provides a direct indication of how much abrasive is being delivered to the wheel. The motor will work harder when delivering more abrasive which causes the motor to draw more current. If the ammeter reads full amperage according to the chart in Section 2 when blasting, the operation is at maximum efficiency. This rating is also listed on the control panel for easy reference.

3.3 Blast Units – Abrasive Control Valve

Refer to chapter 14: Magnetic valve unit.

The abrasive control valve regulates the amount of abrasive delivered to the blast wheel. The main component of this device is a butterfly valve surrounded by a magnetic strip, which when closed, seals off the abrasive flow. A slight gap exists between the disk on the butterfly assembly and the inner wall of the valve. When the disk is horizontal, the magnet provides a seal that closes the gap with steel shot and stops the flow of abrasive. The valve is manually operated from the right side of the control panel and can be adjusted so that the maximum amperage can be obtained by fully opening the valve. A series of mechanical stops are incorporated in the valve actuator, which allows for this adjustment.

3.4 Blast Units – Rebound Chamber (Plenum)

Once the abrasive has impacted the work surface, the shot is directed into the rebound plenum. This curved portion of the machine absorbs a large percentage of the force exerted by the high velocity abrasive and helps dissipate the heat generated by the blast process. Once the abrasive and contaminant mixture reaches the top of the rebound plenum, it enters the separator.



Operating Instructions

1-10D/1-10DSMKIII
& 1-15D/1-15DSMKIII

Description and Function

3.5 Blast Units – Separator

Once the contaminated abrasive leaves the rebound plenum, it enters the separator and immediately encounters the deflector plate. The deflector plate slows the abrasive down even more before it enters a tray at the bottom of the deflector plate. The contaminated abrasive hits the abrasive already at the bottom of the plate and effectively absorbs any residual force left in the moving mixture. The contaminated abrasive then falls through a curtain of high velocity clean air, which physically separates the heavy abrasive and the lighter contaminants. The air wash pulls the contaminants through the separator towards the exhaust and eventually to the dust collector. The clean abrasive falls to the bottom of the separator, then into a hopper where it can be reused.

3.6 Blast Units – Abrasive Seals

Magnetic seals are present on three sides of the rectangular opening at the bottom of the blast housing. These magnets are charged with a load of abrasive and draw any loose abrasive onto their surface, thus providing a “seal” to help contain the high impact abrasive from the surface being cleaned. The fourth side, located at the rear of the machine, has a skid plate attached. This skid plate drags across the work surface and allows clean air to be drawn inside the machine for cooling and to assist in the reclamation process.

3.7 Blast Units – Chassis

All components on the blast unit are mounted on a mobile transporter. This transporter, or chassis, is a three-wheel, self-propelled unit, powered by a 1/4 horsepower electric DC gearmotor. This motor, with its self-contained gear reducer, transfers power to the drive wheel via a chain and sprocket. The operator sets the speed of this motor by varying the setting of the speed control potentiometer located on the blast unit handle. A quick release pin located on the drive wheel sprocket engages the chain drive and can be removed to allow the machine to free wheel.

The machine has two lifting holes located at the top of the rebound plenum and the motor mounting bracket. These lifting eyes allow the machine to be easily raised and lowered for maintenance and transportation.

The operator’s handle (steering handle) contains a lifting cam to allow the operator to lift the blast seal over small obstructions. Once the machine is raised in this manner, gravity will force it down once the obstruction has been cleared. Also located on this handle are the traverse function controls. These are outlined in the following section, “Operator Controls”.



Operating Instructions

**1-10D/1-10DSMKIII
& 1-15D/1-15DSMKIII**

Description and Function

3.8 Blast Units – Electrical Control Panel

This panel was designed to safely operate in the range of 3 phase, 60 Hertz voltages (208, 230, 460 and 480) typically available in the U.S.

This control panel features “Auto Voltage Sensing” (AVS) circuitry developed to protect the equipment and operating personnel. Operator interface elements on the control panel give an indication of “Proper Rotation” or “Improper Rotation”. A digital voltmeter displays the voltage being presented to the equipment. The AVS circuitry will not allow the equipment to operate unless the rotation is correct and the “Voltage Setup” switch is properly set for the incoming power.

After proper rotation is established, the operator has only to operate the “Voltage Selector” switch to the “Low” or “High” position as indicated to start the equipment. This “Voltage Setup” switch connects the windings of the motor(s) and control power transformer for “High” or “Low” voltage. The AVS circuit will prevent a wrong setting of the “Voltage Selector” switch either prior to startup or during operation. A wrong setting prior to startup will not allow the system to energize. If switched during operation, the system will simply “turn off”.

The control panel on the blast unit is provided with the following controls, instruments and components used to operate, monitor and safeguard the operator and the unit.

Main Disconnect Switch – Connects/disconnects power to the blast unit.

Emergency Stop Switch – This is a “push to operate/pull to reset”, red operator. It provides for an immediate shutdown of all elements of the blast unit.

Voltage Selector Switch – Connects the control transformer and blast motor leads for the “Low” or “High” voltage being used.

Improper Rotation Pilot Light – This red pilot light indicates the phase rotation is improper.

Proper Rotation Pilot Light – This green pilot light indicates the phase rotation is correct.

Control Power Pilot Light – This green pilot light indicates the phase rotation is correct, the “Voltage Select” switch position is proper and the AVS circuit is satisfied. The machine is electrically set up and ready to run.

Digital Voltmeter – Provides voltage readout and evaluates the voltage level being presented to the blast unit. Provides information to internal circuitry that protects the system from being inadvertently connected to the wrong voltage.



Description and Function

3.8 Continued

Phase Monitor – Provides phase sequence (rotation) and phase loss protection. Will not allow the system to start unless rotation is correct and all three phases are present.

Analog Ammeter – Provides readout of how much current the wheel motor is drawing. This allows the operator to more precisely monitor and control abrasive flow.

Motor Start / Stop Buttons - Allows operator to start or stop the wheel motor with 120 volt control voltage circuitry.

Abrasive Control Valve Throttle - Used to open or close abrasive butterfly valve that controls the flow of abrasive.

Traverse Control Array – This array of controls is located on the handle of the unit. With it the blast unit's travel can virtually be controlled with one hand. The control elements of this array consist of:

Traverse Switch (Deadman Switch) – This lever actuated switch enables/disables the DC drive control board located in the control panel. The default direction is forward when this switch is actuated. If the operator releases the steering handle switch, the traverse motor is disabled.

Reverse Switch – This momentary pushbutton switch must be operated in conjunction with the Traverse Switch. When depressed along with the Traverse Switch, the unit will travel in the reverse direction.

Speed Potentiometer – This is a rotary device, scaled 1 – 10, that controls the traverse speed of the blast unit in percentages of the maximum travel speed.

Overdrive Switch – This selector switch is operated in the “Normal” position when the operator is controlling the machine speed with the potentiometer. When switched to the “Overdrive” position, the machine traverses at a preset maximum speed.

Fuseless Coordinated Motor and Circuit Protection – This control system was designed to comply with the National Electric Code as a “multi-motor and other loads” branch circuit. The control elements in this system have minimum withstand rating of 50 kA when the branch circuit providing power is protected with a listed fuse or breaker of equal or greater rating.



Operating Instructions**1-10D/1-10DSMKIII
& 1-15D/1-15DSMKIII**

Description and Function

3.9 Dust Collector – General

This Blastrac Model Series, including the 1-10DMKIII, 1-10DSMKIII, 1-15DMKIII and 1-15DSMKIII, shall not be used for blast cleaning unless it is attached to a proper air exhaust hose and dust collector. A special Pulse Jet Dust Collector, Model 654, has been designed to operate in conjunction with this series of Blastrac blast units.

The 654 Dust Collector is normally attached to the blast unit with 50 feet of 5-inch diameter flexible exhaust hose. This dust collector is designed to be able to fit through a 34-inch door opening and is mounted on a mobile chassis. During actual operation, the blast unit cleans in a radial area around the dust collector. Once an area is cleaned, the entire system is moved to an adjacent area to repeat the process. During some applications, the dust collector may be parked in an adjacent room and connected with a longer hose. This procedure is usually done on steel surfaces where less dust and contaminants are being removed. Blastrac does not recommend using more than 50 feet of hose on concrete surfaces. Consult with your Blastrac representatives if you have a particular application that requires a longer exhaust hose. The 654 Dust Collector is comprised of the following elements:

- Filter Chamber
- Dust Bin
- Blower
- Minihelic Gauge
- Pulse / Pressure System
- Chassis
- Electrical Control Panel

3.10 Dust Collector – Filter Chamber

The central part of the dust collector is the filter chamber. Dust laden air enters the chamber from the blast machine through the exhaust hose and into the vent hose connection located at the bottom left from the control panel. The dirty air passes through a plenum and flows through an array of six vertically mounted, specially designed filter cartridges. Dust is captured on the surface of these filters allowing clean air to pass to the clean air portion of the dust collector where it exhausts to the open atmosphere.



Operating Instructions

1-10D/1-10DSMKIII
& 1-15D/1-15DSMKIII

Description and Function

3.10 Continued

The dust that was trapped on the external surface of the filters is periodically removed by pulsing the filters with an internally supplied burst of compressed air. This momentary pulse of air allows the dust to fall into a hopper at the bottom of the filter chamber. Two filters are pulsed at a time, in sequence, determined by a timer board located in the control panel. This timer board is usually set to pulse a two filter bank every ten seconds and allows the pressurized air reservoir to drop about 30 PSI during each pulse. The timer board determines the time between pulses and the length of each pulse. Venturies are located above each filter for maximum filter cleaning efficiency.

3.11 Dust Collector – Dust Bin

Once the dust falls to the bottom of the chamber, it collects in a special disposal bin that can be removed. The dust collector must be turned off before removing the dust bin from the machine for dust disposal. Care should be taken to ensure that the dust bin does not overflow. Filter damage can occur if the dust level exceeds the top of the dust bin.

The dust bin is equipped with wheels and a handle to assist when disposing of the dust. Care should be taken when loosening the clamps. A full dust bin can hold approximately 200 pounds of material.

3.12 Dust Collector – Blower

The blower (exhaust fan) is mounted on top of the dust collector chassis and is powered by a five horsepower electric motor. The blower moves approximately 540 cubic feet of air per minute at peak efficiency.

3.13 Dust Collector – Minihelic Gauge

A gauge is mounted on the electric control panel, which measures the differential pressure across the filters. As the filters age and become saturated, the reading on this gauge will increase. During normal operation, this gauge should read between zero and four inches. A consistent reading between four and six inches signifies that the filters should be changed soon. A reading of more than six indicates that the filters need to be changed immediately.



Operating Instructions

1-10D/1-10DSMKIII
& 1-15D/1-15DSMKIII

Description and Function

3.14 Dust Collector – Pulse Pressure System

A direct driven, 3/4 horsepower, maintenance free air compressor with external pressure regulation is mounted beneath the control panel on the dust collector. The pressure of this system is determined by the setting of the unloader valve located on the pressure side of the compressor. Compressed air is delivered to an air reservoir located inside the dust collector's clean air compartment. Three Goyen (diaphragm) valves are located above the air reservoir and are activated by a timer board located inside the control panel. The timer board actuates one of three sequentially operated pilot solenoids located on the left side of the control enclosure. These pilot solenoid valves in turn release the pressure held by the Goyen valves, allowing a pulse of air to be directed downward through the Venturi ports to pulse the filter cartridges. This air pulse cleans the filters sequentially as described in the filter chamber paragraph. The pressure setting on this system is set at a maximum pressure of 80 PSI. If the pressure goes above 125 PSI, an in-line pressure safety valve will open to protect the pressure components.

3.15 Dust Collector – Chassis

The entire dust collector is mounted on a mobile chassis resting on four castors. Two swivel castors are mounted beneath the air inlet for ease in maneuverability and the opposite castors are rigid. The upper frame is equipped with four lifting eyes to help raise and lower the machine for transportation.

NOTE: The dust collector is not designed for vehicle towing or movement on roads.

3.16 Dust Collector – Electrical Control Panel

The control panel for the 654 Dust Collector is mounted on the front chassis. This panel was designed to safely operate in the range of 3 phase, 60 Hertz voltages (208, 230, 460 and 480) typically available in the U.S.

This control panel features "Auto Voltage Sensing" (AVS) circuitry developed to protect the equipment and operating personnel. Operator interface elements on the control panel give an indication of "Proper Rotation" or "Improper Rotation". A digital voltmeter displays the voltage being presented to the equipment. The AVS circuitry will not allow the equipment to operate unless the rotation is correct and the "Voltage Setup" switch is properly set for the incoming power.



Description and Function

3.16 Continued

After proper rotation is established, the operator has only to operate the “Voltage Selector” switch to the “Low” or “High” position as indicated to start the equipment. This “Voltage Setup” switch connects the windings of the motor(s) and control power transformer for “High” or “Low” voltage. The AVS circuit will prevent a wrong setting of the “Voltage Selector” switch either prior to startup or during operation. A wrong setting prior to startup will not allow the system to energize. If switched during operation, the system will simply “turn off”. This “High” or “Low” voltage switch is for the 654 dust collector only.

The control panel on the 6-54 Dust Collector is provided with the following controls, instruments and components that are needed to operate, monitor and safeguard the operator and the unit.

Main Disconnect Switch – Connects/disconnects power to both the dust collector and the blast unit.

Emergency Stop Switch – This is a “push to operate/pull to reset”, red operator. It provides for an immediate shutdown of all elements of the dust collector system.

Voltage Selector Switch – Connects the control transformer and motor leads for the “Low” or “High” voltage being used.

Improper Rotation Pilot Light – This red pilot light indicates the phase rotation is improper.

Proper Rotation Pilot Light – This green pilot light indicates the phase rotation is correct.

Control Power Pilot Light – This green pilot light indicates the phase rotation is correct, the “Voltage Select” switch position is proper and the AVS circuit is satisfied. The machine is electrically set up and ready to run.

Digital Voltmeter – Provides voltage readout and evaluates the voltage level being presented to the dust collector unit. Provides information to internal circuitry that protects the system from being inadvertently connected to the wrong voltage.

Phase Monitor – Provides phase sequence (rotation) and phase loss protection. Will not allow the system to start unless rotation is correct and all three phases are present.



Operating Instructions

1-10D/1-10DSMKIII
& 1-15D/1-15DSMKIII

Description and Function

3.16 Continued

Compressor Start / Stop Buttons – Allows the operator to start or stop the compressor with 120 volt control voltage circuitry.

Blower Start / Stop Buttons – Allows the operator to start or stop the blower with 120 volt control voltage circuitry. Also energizes the timer board and associated circuitry. The dust collector will not pulse unless the blower is running.

Elapsed Time Meter – Provides an indication of “run time” of the blower.

Fuseless Coordinated Motor and Circuit Protection – This control system was designed to comply with the National Electric Code as a “multi-motor and other loads” branch circuit. The control elements in this system have minimum withstand rating of 50 kA when the branch circuit providing power is protected with a listed fuse or breaker of equal or greater rating.

3.17 Dust Collector – Ventilation System

A controlled flow of air must pass through the blast unit and the 654 Dust Collector during normal operation for the reasons listed below:

- Cools blast machine components.
- Helps remove residual abrasive and dust from work surface.
- Collects and separates dust and contaminants from recycled abrasive.
- Transports dust and contaminants to dust collector.

Ventilation air must follow a designed path through the machine(s). Any irregularities in the path can affect the performance of the system. The air sequence follows:

Air enters the area around the rear skid seal of the blast unit at a high velocity and helps sweep residual abrasive and dust from the work surface.

This air traverses up the rebound plenum and into the separator. The air movement up the rebound plenum helps keep the abrasive and the chamber walls cool.

The separator also has three clean air ports that are used to direct clean air through the internal air wash. These ports are located at the sides and front of the separator.



Description and Function

3.17 Continued

The dust-laden air from the air wash is directed through the separator and into the flexible hose.

The hose delivers the contaminated air to the dust collector where the air is filtered and returned to the atmosphere.

The ventilation system should be monitored on a regular basis. Bad or improper ventilation can lead to poor component life and premature wear on a number of ventilation related items on the equipment. Some of the more important areas to monitor, relative to the ventilation system, are:

The skirts around the blast housing should be kept in good repair.

The seals around the separator lid should be checked regularly.

The hose connections to the blast unit and the 654 Dust Collector should be tight and held in place with metal clamps.

The hose should be kept in good repair. Flattened spots, holes and wear spots should be corrected immediately. Replace hose if necessary.

Ventilation leaks on the blower assembly seal and especially the dust bin seal should be minimized. The dust bin seal can be checked by feeling for air leaks around the seal and evidence of dust leaks.

Any ventilation irregularities can have an adverse effect on the overall performance and efficiency of the system. Improper ventilation can cause poor abrasive cleaning which in turn increases blast wheel and liner wear. An important fact that is often ignored or misunderstood is:

The steel abrasive causes minimum wear on the internal blast components. The dust and contaminants are the principal cause of component wear. A well-maintained ventilation system can minimize abrasive contamination which helps reduce operating costs and increases the overall efficiency of the shotblasting system.



Operating Instructions

**1-10D/1-10DSMKIII
& 1-15D/1-15DSMKIII**

Start-Up Procedures

Section 4

- 4.1 Start-Up Procedures
- 4.2 Blast Cleaning
- 4.3 Shut Down



Operating Instructions

1-10D/1-10DSMKIII
& 1-15D/1-15DSMKIII

Start-Up Procedures

4.1 Start-Up Procedures

Note:

All operators and maintenance personnel should read and understand the entire Operating Instructions Manual before attempting to operate or maintain this machine. Pay close attention to all safety instructions, dangers, warnings and cautions. **Also, Blastrac highly recommends that all operating and maintenance personnel receive a thorough training regimen from an authorized Blastrac representative before attempting to operate or maintain this equipment.**

Start-Up

Warning: Machine power should be disconnected before any and all machine inspections. Failure to disconnect power may result in serious injury.

1. The blast unit and dust collector should be moved to the cleaning site. Both machines can be hand-towed or moved by lift truck. When the blast unit is not powered, always disconnect the drive pin from the traction drive hub prior to moving. This will avoid the possibility of gearmotor damage.
2. Check the dust bin of the dust collector to be sure that it is empty. At the end of each job, the dust bin should be emptied.
3. Check the shot hopper of the blast unit to be sure that the shot has been drained. At the end of each job, the shot hopper should be emptied.
4. Check the blast wheel, control cage, feed spout, liners, seals and hopper parts for wear. Replace parts where necessary.
5. Inspect the electrical cables and connectors for damage, cuts, abrasions or wear. Replace all defective items before continuing.
6. Check the exhaust hose for holes, deformities, potential leaks or restrictions. Repair or replace all defective items before continuing.
7. Connect the exhaust hose and clamps to the blast unit and the dust collector. Be sure the clamps are secure.
8. While this equipment is provided with voltage sensing and phase monitoring, it is good practice to check the voltage source prior to presenting power to the equipment. Use a reliable voltmeter for this check. This equipment will operate

Start-Up Procedures

4.1 Continued

normally on $\pm 10\%$ of the low or high voltage range. If the supply voltage is a nominal 208 to 240 volt, the measured voltage should not be less than 187 volts, nor more than 264 volts. If the supply voltage is a nominal 460 to 480 volt, the measured voltage should not be less than 414 volts, nor more than 528 volts. The site voltage must be corrected if it is above or below these parameters. **NOTE:** Site power during motor startup must not drop below the minimum voltages (187 volts or 414 volts).

9. Connect the umbilical cable to the dust collector and blast unit. Inspect each connector prior to connecting. If damage has occurred, replace the component before proceeding. Assure the connectors are fully engaged and latched. Assure the strain relief on each end of the umbilical is securely fastened to the frame of the dust collector and blast unit using the hardware provided.
10. Check the main disconnect switches on both machines. Assure they are both in the "OFF" position.
11. Check the voltage setup switches on both machines. Assure they are both in the "OFF" position.
12. The amperage requirement of your Blastrac system is detailed in the "Operator Responsibility" section of this manual. Assure this requirement is met. If the circuit protection is too small for the load, undue stress will be applied to the circuit and the equipment will not operate properly. If the circuit protection exceeds the recommendation, an unsafe condition will be created.
13. **Proper grounding is critical to personnel safety.** Be absolutely certain that the green ground wire on the dust collector power cable is properly terminated to the site power ground bus. If a generator is to provide power, assure that the generator manufacturer's grounding instructions are followed. **Serious injury can result from inadequate equipment grounding.** Once the power cord is connected and checked, energize the power source.
14. Check the area you are about to clean. Be sure that it is free of all debris that can clog or damage the equipment. Be sure that the surface is moisture free. Blastrac machinery is designed to work on clean, dry surfaces only.

4.1 Continued

15. Make certain that the abrasive valve operator on the right side of the control panel is in the closed position. Remove the separator lid and check that the shot hopper is free of debris and abrasive. Remove the screens and check the butterfly valve at the bottom of the hopper. It should be in the horizontal position. Replace the screens and add approximately 40 pounds of abrasive. The level of this abrasive should reach the bottom of the boxed screen. **Do not overfill.** Replace the separator lid.
16. Turn the dust collector main disconnect switch to "On". Set the Emergency-Stop switch by pulling it until it is latched. This will allow the control system to begin an initiation/measurement sequence to determine phase sequence and measure the incoming voltage. While this equipment contains a phase monitoring device that will help assure proper rotation of the motors, a quick rotation check should always be made prior to the blast operation. Observe the pilot lights indicating "Proper Rotation" (Green) and "Improper Rotation" (Red). If the red "Improper Rotation" comes on, two of the three power wires, black, red or white (not green) connected to site power, must be reversed to correct the phase sequence (rotation). **Disconnect power before reversing the leads.** If the green "Proper Rotation" light is on, the operator may proceed. **NOTE*** New Blastrac machines are factory tested to assure both machines have the same motor rotation. Changing the two hot leads at the power source will reverse the motor rotation of all three electrical motors. However, if machines are mated with machines other than the original pair, they may rotate in opposite directions. Always check the motor rotation of both machines before starting up at a new job site or whenever moving from the original customer furnished power source. **The rotation can change from different locations inside the same building, so be sure to always make this critical check.**

In the event a motor has been repaired or replaced, the rotation of the motor as compared to the Phase Monitor will have to be confirmed. Refer to the electrical schematic for detailed instructions.

17. Observe the digital voltage readout located on the dust collector control panel. If the indication is between 187 and 264 volts, set the "Voltage Select" switch to "Low Volts". If the indication is between 414 and 528 volts, set the "Voltage Select" switch to "High Volts". If the setup is correct, the "Control Power" light (amber) will illuminate. This indicates that control power is present and the machine is ready to

Start-Up Procedures

4.1 Continued

be started. **NOTE:** Site power during motor startup must not drop below the minimum voltages (187 volts or 414 volts).

CAUTION: BE SURE ALL ELECTRICAL DISCONNECTS ARE LOCKED IN THE "OFF" POSITION AND THAT ALL ROTATING PARTS ARE FULLY STOPPED BEFORE WORKING IN PANELS.

18. Check the operation of the dust collector. The air pressure should build up to 80 PSI maximum and the filters should be pulsed every 10 - 11 seconds. The pulse duration and the time between air pulses is determined by the timer board setting which is located inside the control panel. The air pressure is determined by the setting of the unloader (pilot) valve located next to the compressor.
19. Turn the disconnect switch located on the front of the blast unit control panel to "On". Set the Emergency Stop switch by pulling it until it is latched. This will allow the control system to begin an initiation/measurement sequence to determine phase sequence and measure the incoming voltage. While this equipment contains a phase monitoring device that will help assure proper rotation of the motors, a quick rotation check should always be made prior to the blast operation. Observe the pilot lights indicating "Proper Rotation" (Green) and "Improper Rotation" (Red). If the red "Improper Rotation" comes on, a system check must be made. If the green "Proper Rotation" light is on, the operator may proceed. Engage the motor start button and check the rotation of the blast wheel motor. Turn off the blast motor and proceed to the next step.
20. Check the magnetic seals on the bottom of the blast unit for metallic contaminants such as nuts, bolt, etc. and remove. Insert the traction drive pin into the traction drive sprocket of the blast unit. At the operator's station, set the travel speed at 1 or 2. Deposit a layer of abrasive on the floor in front of the magnets. Engage the traction drive using the limit switch located below the steering handle. Drive the machine over the abrasive to charge the magnets with a layer of shot. The shot will form a seal between the magnets and the floor. Remove any excess abrasive from the floor.
21. Engage the start buttons for the blower, the compressor and the blast wheel. Again, at the operator's station, set the travel speed at about midpoint for the initial test of the operation. Once the machine is moving, ease the abrasive valve open and observe the ammeter. **Do not exceed the recommended amperage that is**



Start-Up Procedures

4.1 Continued

determined by the operating voltage. The opening of the abrasive valve determines how much abrasive enters the blast wheel. As more abrasive flow is selected, the motor amperage will increase since the motor has to work harder. The abrasive control valve operator should be adjusted so that the fully open position can coincide with the full load amperage of the motor. This setting can vary from machine to machine and with the size of abrasive being used.

22. After cleaning a five-foot test strip, close the abrasive valve, stop the machine and check the cleaned area.
23. If the brightness or texture of the test strip is uneven, refer to Section Five, "Blast Pattern", to adjust the "HOT SPOT".

4.2 Blast Cleaning

1. Engage the traction drive by compressing the lever actuated limit switch below the steering handle. Ease the abrasive valve open while monitoring the ammeter readout. Do not exceed the amperage rating for the operating voltage. The operator will be walking backwards to operate the machine in the forward direction.
2. If the cleaning is too severe or inadequate, adjust the travel speed. A faster setting will result in a lighter surface profile while a slower speed will be more aggressive and permit a deeper profile. If irregular surfaces are encountered, adjust the speed accordingly. (See Section 6 - Equipment Calibration)
3. The blast unit is maneuvered so that the dust collector is centrally located. Blasting in straight lines will always give the best, most consistent results. Keep the duct hose situated between the two units so that you never have to pass across it or the power cord.

Caution: Do not allow any type of equipment to run over the power cable or the exhaust hose. Always avoid long power cord extensions. Contact a Blastrac representative for extension cord details.



Operating Instructions

1-10D/1-10DSMKIII
& 1-15D/1-15DSMKIII

Start-Up Procedures

4.2 Continued

Blasting during a turn will create an uneven profile. Once an area has been cleaned, the blast unit and the dust collector can be moved to an adjacent location to continue cleaning.

4. The blast unit will clear small obstructions by pushing down on the steering handle. **Caution should be observed when clearing obstructions in this manner since the abrasive seal on the work surface may be broken. This may allow high velocity abrasive to escape.**

4.3 Shut Down

1. Close the abrasive valve.
2. Release the limit switch lever on the steering handle to stop the forward progress of the machine.
3. Turn off the blast wheel and move the blast unit disconnect switch and "Volt Select" switch to the "Off" position.
5. Go to the dust collector and turn off the blower and the compressor. Move the dust collector disconnect switch and the "Volt Select" switch to the "Off" position.
6. Check dust level in the dust collector dust bin regularly, at intervals determined by monitoring the amount of removal being done.
7. At the end of each job, the dust bin and the shot hopper should be emptied.



Operating Instructions

**1-10D/1-10DSMKIII
& 1-15D/1-15DSMKIII**

Setting the Correct Blast Pattern

Section 5

5.1 Setting the correct blast pattern

Setting the Correct Blast Pattern

5.1 Setting the correct blast pattern

Setting the correct blast pattern is essential before an even, clean profile can be achieved when shot blasting with a Blastrac machine. An uneven blast pattern can leave shadows on either side of the floor surface and can cause premature wear to the internal components. The importance of setting the proper blast pattern cannot be overstressed.

There are four major factors that can affect the blast pattern. They are:

1. **Wheel Rotation** - The blast wheel must be rotating in the proper direction indicated on the housing that surrounds the blast wheel. Most Blastrac machines rotate in a counter-clockwise direction when looking at the machine from the operator's position.
2. **Worn Wheel Kits** - Wheel kit components such as blades, impellers and control cages vary in different machines but perform similar functions. These kits must be periodically replaced to ensure that they provide the proper blast pattern and to eliminate excessive wear, which can cause internal component and bearing unit damage.
3. **Abrasive Size** - The size of the abrasive can affect the blast pattern. Different sized abrasives have different mass characteristics that can alter the "hot spot" setting. See Figure B.
4. **Control Cage Setting** -The setting of the control cage is the most critical factor in determining where the blast pattern is directed. Ideally, the blast pattern is centered so that the area being cleaned receives a consistent, even distribution of high velocity abrasive. Altering the setting of the control cage can move the blast pattern to the left or right depending on which direction the control cage is moved. Moving the control cage too far in either direction will direct the abrasive blast pattern to the side of the machine and cause premature wear to the internal components. The exact positioning of the control cage is done by trial and error. The initial setting of a machine rotating in a counter-clockwise direction should be between 11:30 and 9:30 as

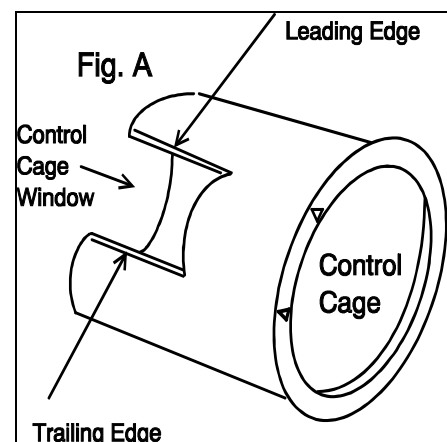

Setting the Correct Blast Pattern

5.1 Cont'd

indicated in the illustrations. The resultant-cleaning path will determine the final setting.

Note: (Machines that rotate in a clockwise direction, such as the Model 1-20D, will have an initial setting between 12:30 and 2:30.)

These settings can vary with the abrasive size and the surface being cleaned. Once the proper control cage setting is obtained, the blast pattern should remain consistent. If the pattern begins to vary, check the blast wheel components for wear.

Control Cage “Trial & Error” Setting

The initial setting of the control cage for a machine that has the blast wheel rotating in a counter-clockwise direction is between 11:30 and 9:30. The leading edge should be at 11:30. Refer to Figures A, B and C. The resulting “hot spot” should be centered as it appears on Figure B. If the “hot spot” is too far to the left, rotate the control cage in a counter-clockwise direction about 1/4” and recheck the blast pattern on the test strip. Small changes in the rotation of the control cage can move the “hot spot” significantly. If the “hot spot” is too far to the right, rotate the control cage in a clockwise direction. Once again, move the control cage in small increments until the blast pattern (“hot spot”) is centered.

Note: If the blast pattern cannot be centered, check the blast wheel and be sure it is properly mounted and seated on the wheel hub located behind the blast wheel. The two pins on the hub must be seated on the back of the blast wheel before the wheel can be secured. This check must be made whenever the blast wheel is changed.

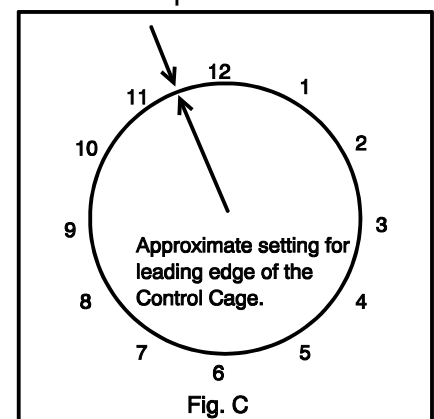
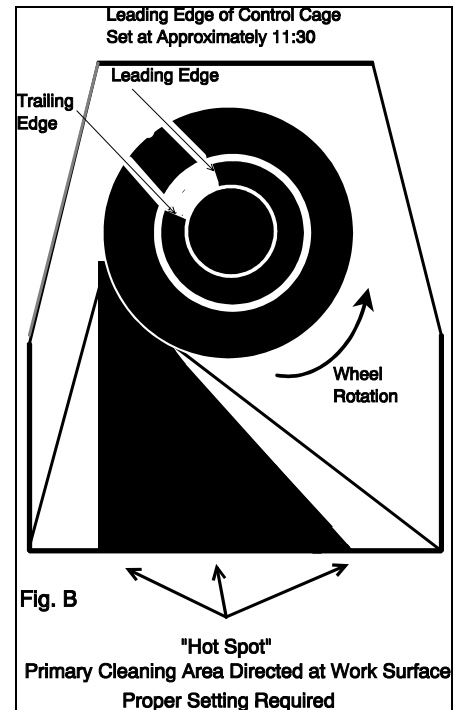



Operating Instructions

**1-10D/1-10DSMKIII
& 1-15D/1-15DSMKIII**

Equipment Calibration

Section 6

6.1 Equipment Calibration



6.1 Equipment Calibration

The following list of recommended set-up adjustments and reference values should be used to help obtain the optimal performance from your blast cleaning system. These should be used as starting points and can be fine-tuned after trial and observation.

CAUTION: CALIBRATION OF ITEMS 1, 2, 6 AND 7 MUST BE MADE WITH ALL ELECTRICAL DISCONNECTS IN THE “OFF” POSITION. ALL MOVING PARTS MUST BE **COMPLETELY** STOPPED BEFORE MAKING ANY ADJUSTMENTS OR PERFORMING MAINTENANCE.

1. **Blast Housing Height** - The bottom of the blast housing (magnets) should be between 1/8” to 1/2” above the surface being cleaned. A smaller clearance can be obtained for smooth surfaces and the height may need to be higher for rough surfaces.
2. **Control Cage Setting** - See Section 5, Setting the Correct Blast Pattern; figures A, B and C.
3. **Abrasive Selection Recommendations** (Steel Shot Size)
 - Brush blast of smooth concrete: S-170 to S-280 (smaller size will produce a brighter etch)
 - Rough concrete etch for coatings: S-330 to S-460
 - Heavy concrete removal: S-460
 - Cleaning scale or paint on steel: S-460
4. **Travel Speed Suggestions** (Speed Control Potentiometer Setting)
 - Brush blasting: 5 to 10 (higher speeds 40 to 85 ft/min)
 - Heavy concrete blast: 3 to 5 (medium speeds 21 to 40 ft/min)
 - Steel surface cleaning: 1 to 3 (slow speeds 6 to 21 ft/min)
5. **Exhaust Hose Length** - 50 feet of 5-inch diameter exhaust hose; longer or shorter sections of hose may affect abrasive consumption or abrasive cleaning. Contact your Blastrac representative before changing the exhaust hose length.



Operating Instructions

**1-10D/1-10DSMKIII
& 1-15D/1-15DSMKIII**

Equipment Calibration

6.1 Continued

6. **Dust Collector Pulse Timer** - Set for approximately 10 seconds for concrete cleaning; 15 seconds for steel cleaning.
7. **Compressor Pressure Setting** - 80 PSI max. The unloader adjustment determines pressure. (30 PSI drop for Pulse)
8. **Pressure Drop Across Filters** - Minihelic gauge should read between 1 and 4 inches. An indication above 4 indicates that the filters are dirty.
9. **Dust Bin Change Interval.** - Inspect at 1/2-hour intervals to estimate fill time. Do not allow dust bin to overflow.
10. **Analog Ammeter** – Calibrate after 50 hours of operation. Warning: only a certified electrician should perform the calibration. The ammeter has a thumb screwed centered below the display. A loop ammeter should be used and the values of the loop ammeter should be compared with the analog values. Adjust the thumb screw until the reading on the analog ammeter is the same as the reading on the loop ammeter. Adjust your calibration schedule as needed; it may not be necessary to calibrate every 50 hours after the first 50 hours of operation.



Operating Instructions

**1-10D/1-10DSMKIII
& 1-15D/1-15DSMKIII**

Wear Parts

Section 7

7.1 Wear Parts



Wear Parts

7.1 Wear Parts

Certain portions of the Blastrac are continuously exposed to high velocity abrasive. These areas and their corresponding parts must be periodically inspected for wear and erosion to keep from damaging components that are not normally exposed to the abrasive blast. These parts are identified on the service drawings later on in this manual along with part numbers. Maintenance personnel design all parts for relatively easy replacement. A preventive maintenance program should be performed to monitor these areas on a regular basis. The following list outlines these areas and the time intervals involved.

Wear Parts Chart

Part	Inspection Interval	Wear Indication
Blast Wheel	5 Hrs.	Blades worn half thickness or more
Feed Spout	50 Hrs.	Thin at Wheel Entry
Control Cage	5 Hrs.	Eroded Edges
Rebound Plenum	100 Hrs.	Thin Portions; Wear on Welds.
Deflector Plate	50 Hrs.	Thin Sections; Wear at Welds
Separator	100 Hrs.	Thin Sections; Wear at Welds; Warp; Screen Wear
Liners	100 Hrs	Thin Sections; Warp
Blast Wheel Hub	When Changing Blast Wheel	Pins Missing or Worn; Wear
Top Cover	50 Hrs.	Inside Edge Erosion
Blast Housing	When Changing Liners	Liners Worn Through; Corners Eroded

Keep in mind that other portions of the machine require periodic inspections and maintenance. The parts mentioned above are associated with the internal abrasive blast. Electrical cable and exhaust hose, for example, also require close inspection and maintenance.



Operating Instructions

**1-10D/1-10DSMKIII
& 1-15D/1-15DSMKIII**

Blast Wheel Replacement

Section 8

- 8.1 Blast Wheel Replacement
- 8.2 Blast Motor Belt Replacement/Adjustment



Operating Instructions

1-10D/1-10DSMKIII
& 1-15D/1-15DSMKIII

Blast Wheel Replacement

8.1 Blast Wheel Replacement

WARNING: ALL ELECTRIC POWER MUST BE DISCONNECTED AND ALL ROTATING PARTS MUST BE COMPLETELY STOPPED BEFORE ATTEMPTING THIS PROCEDURE.

1. Release the two locking cams that secure the feed spout and slide the straps away. Remove the feed spout.
2. Remove the two control cage clamps and then remove the control cage.
3. Outline the area around the control cage mounting assembly with a marking pen or pencil. This will allow for easier alignment when reinstalling this part later during this procedure. Remove the four mounting nuts, flat washers and lock washers that secure the control cage mounting assembly to the blast housing. Do not loosen any other screws on the control cage mounting assembly since they are used to set the gap between the blast wheel and the control cage. Remove the control cage mounting assembly.
4. Remove the socket head cap screw and spherical washers from the blast wheel and remove the blast wheel.
5. Check the wheel hub for wear and replace if necessary.
6. Install new blast wheel using the new socket head cap screw and spherical washers that are included in the wheel kit. Be sure that the new blast wheel is seated properly on the wheel hub before tightening the socket head cap screw.
7. Reinstall the control cage mounting assembly to the blast housing using the outline made before removing the assembly.
8. Install the new control cage that is included with the wheel kit. Rotate the wheel by hand to be sure the control cage and the wheel do not make contact. The initial window setting for the control cage should be between 9:30 and 11:30.
9. Reinstall the feed spout.



Operating Instructions

1-10D/1-10DSMKIII
& 1-15D/1-15DSMKIII

Blast Wheel Replacement

8.1 Cont'd

10. Energize the blast motor momentarily to check for good balance and proper clearance before shotblasting.

11. See Section 5, "Blast Pattern", before adjusting the control cage for the correct blast pattern.

The assembly of the blast wheel and its associated parts is the Spare Parts section of the Operating Instructions. These parts must be maintained in good operating condition in order to enhance the life of the bearing unit and the electric motor that are used to deliver power to the blast wheel. Blastrac parts are supplied in a state of accurate balance with machined surfaces for safe, reliable operation.

8.2 Blast Wheel Motor Belt Adjustment/Replacement

WARNING: ALL ELECTRIC POWER MUST BE DISCONNECTED AND ALL ROTATING PARTS MUST BE COMPLETELY STOPPED BEFORE ATTEMPTING THIS PROCEDURE.

See Figure 8.2 "Wheel Drive Components" for part identification.

1. Remove belt guard by removing the two acorn nuts (ITEM 1).
2. Loosen the four hex head bolts (ITEM 2) that connect the blast wheel motor to the motor bracket. **DO NOT REMOVE THE BOLTS COMPLETELY.**
3. Loosen the socket head screw (ITEM 3) that connects the eccentric sleeve (ITEM 4) to the blast wheel motor. **DO NOT REMOVE THE SCREW COMPLETELY.**
4. Use the hex head bolt (ITEM 5) located in the center of the eccentric sleeve (ITEM 4) to adjust the belt tension. Rotating the hex head bolt (ITEM 5) **counter-clockwise** will loosen the belt. Rotating the hex head bolt (ITEM 5) **clockwise** will tighten the belt.



Operating Instructions

1-10D/1-10DSMKIII
& 1-15D/1-15DSMKIII

Blast Wheel Replacement

8.2 Cont'd

5. To remove the belt, rotate the hex head bolt (ITEM 5) on the eccentric sleeve (ITEM 4) **counter-clockwise** until the socket head screw (ITEM 3) is in the 6:00 position or directly below the hex head bolt (ITEM 5).
6. Remove the belt from the sheaves. **Never force the belt off the sheaves.** Always release enough tension from the belt so it will slide off the sheaves easily.
7. **Before replacing the belt, inspect the condition of the sheaves.** Dusty, rusty or worn sheaves can reduce the belt life up to 50%. To replace and tension the belt, place belt around sheaves and rotate the hex head bolt (ITEM 5) on the eccentric sleeve (ITEM 4) **clockwise** to increase the belt tension. See Figure 8.2 "Belt Tension Requirements" for correct belt tension. Never force the belt on the sheaves. Forcing the belt can cause internal damage to the belt. **BE SURE THAT THE BELT IS SECURE IN THE GROOVES OF THE SHEAVES BEFORE CONTINUING.**

Blast Wheel Replacement

8.2 Cont'd

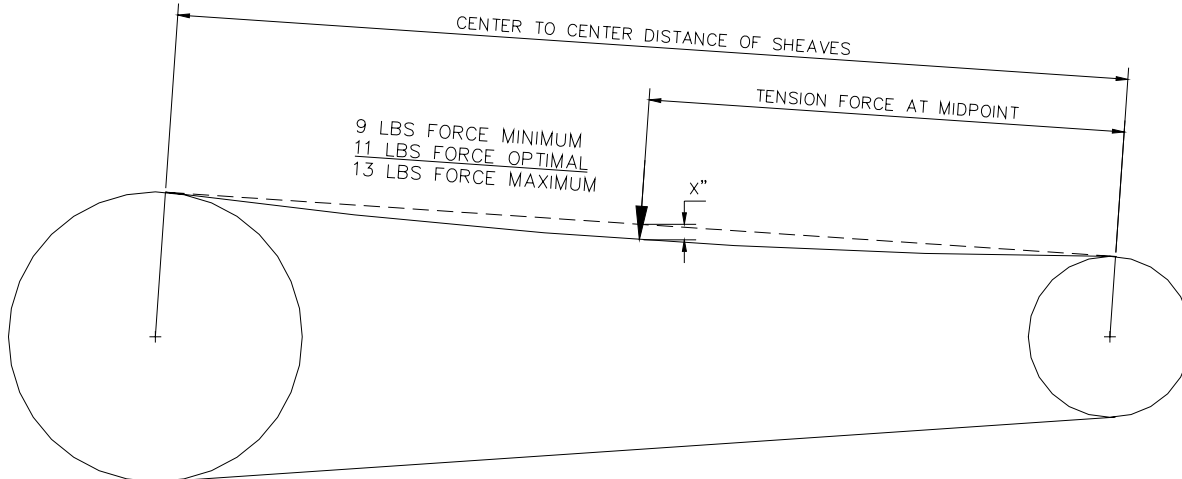

FIGURE 8.1 Belt Tension Requirements

Belt Tension

The correct belt tension is important for the life of the belt, sheaves and wheel bearing unit. Too much belt tension will reduce the operating life of these components. The correct belt tension is also important for the efficiency of power transmission. If the belt does not have enough tension, the belts may slip causing a decrease in production and an increase in belt and sheave wear. **As seen in Figure 8.1, the optimal tension for this system is 11 lbs of force.** The belt should deflect 1/64" per inch of "center-to-center" distance of the sheaves under the optimal tension force. For example, if the "center-to-center" distance of the sheaves was 64" then 64/64 would equal 1" of deflection under the optimal tension force. Measure the "center-to-center" distance of the sheaves and divide by 64. This will be your desired deflection with 11 lbs of force. **This particular system should deflect approximately 1/4" with 11 lbs of force.** It is recommended that a V-belt tension tester is used when adjusting the belt tension. V-belt tension testers are inexpensive and may be purchased from most V-belt manufacturers.

8. After the belt is properly tensioned, tighten the socket head screw (ITEM 3) that connects the eccentric sleeve (ITEM 4) to the blast wheel motor and the four hex head bolts (ITEM 2) that connect the blast wheel motor to the motor bracket.

Blast Wheel Replacement

8.2 Cont'd

9. Replace the belt guard. **NEVER OPERATE THE MACHINE WITHOUT THE BELT GUARD IN PLACE.**
10. Check the belt tension after 50 hours of run time after replacing the belt. This "run-in" time will reduce the tension of the belt. The belt tension should be adjusted back to the optimal belt tension as described above.

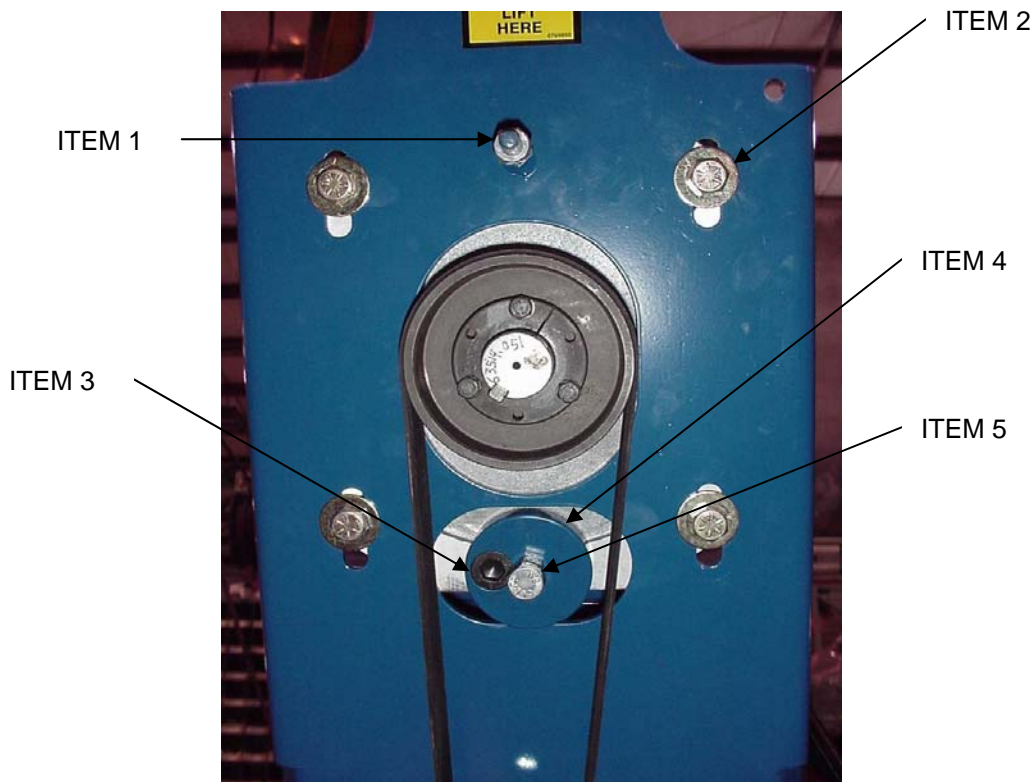

FIGURE 8.2 Wheel Drive Components



Operating Instructions

**1-10D/1-10DSMKIII
& 1-15D/1-15DSMKIII**

Lubrication

Section 9

9.1 Lubrication



Operating Instructions

1-10D/1-10DSMKIII
& 1-15D/1-15DSMKIII

Lubrication

9.1 Lubrication

The bearing unit that is located directly behind the blast wheel outside the blast housing must receive periodic lubrication. This unit operates at a relatively high temperature (200 degrees Fahrenheit) and requires the use of a **high temperature, lithium based grease**. Mobilux 77 EP-2 is one example.

The bearing unit should receive several pumps of this high temperature, lithium based grease at least every 50 hours. Several pumps of grease from a standard grease gun should be sufficient.

The grease needs to be inserted at both ends of the bearing unit where the grease fittings are located. Once the unit is greased, run the blast wheel for 10 - 15 minutes to purge any excess grease.

Do not over-grease this unit.



Operating Instructions

**1-10D/1-10DSMKIII
& 1-15D/1-15DSMKIII**

Troubleshooting

Section 10

- 10.1 Troubleshooting
- 10.2 Ventilation System (6-54 Dust Collector)
- 10.3 Vacuum Adjustment – Operating Tips

Troubleshooting

10.1 Troubleshooting

Note: All operators and maintenance personnel should read and understand the entire Operating Instructions Manual before attempting to operate or maintain this machine. Pay close attention to all safety instructions, dangers, warnings and cautions.

Troubleshooting List...Blast Unit...Mechanical Malfunctions

Trouble	Probable Cause	Remedy
Excessive noise. Usually indicates misaligned components which causes premature wear and component failure.	<p>Improper clearances or alignments between rotating parts, usually the control cage and the blast wheel.</p> <p>Loose bolts or misalignment.</p>	<p>Check alignment of control cage and wheel. Allow sufficient clearance between rotating parts.</p> <p>Check bearing unit, belts, sheaves, motor mounting, wheel housing and any other associated parts to be sure of alignment and that they are firmly secured.</p>
Excessive noise. Usually indicates misaligned components which causes premature wear and component failure.	<p>Improper clearances or alignments between rotating parts, usually the control cage and the blast wheel.</p> <p>Loose bolts or misalignment.</p>	<p>Check alignment of control cage and wheel. Allow sufficient clearance between rotating parts.</p> <p>Check bearing unit, belts, sheaves, motor mounting, wheel housing and any other associated parts to be sure of alignment and that they are firmly secured.</p>

Troubleshooting

10.1 Continued

Trouble	Probable Cause	Remedy
Increased cleaning time.	Improper abrasive feed to wheel.	Check ammeter reading. Low reading indicates insufficient abrasive getting to wheel.
	Storage hopper.	Check abrasive level.
	Contaminated abrasive.	Abrasive may contain substantial percentage of fines and contaminants. Check ventilation.
	Abrasive feed and abrasive control valve.	Check for obstructions in the abrasive feed, i.e. feed spout, abrasive control valve, separator screen.
	Wheel impeller, control cage wear.	Replace wheel kit.
	Drive belt.	Check belt for proper tension, alignment or wear.
	Loss of consistent blast pattern, "hot spot".	Check blast pattern. Check the blast wheel for proper seating with the wheel hub.
	Choked wheel.	Close abrasive valve and gradually reopen. Check abrasive valve operation, check "over-amping" blast wheel.

Troubleshooting

10.1 Continued

Trouble	Probable Cause	Remedy
Excessive wear on blast housing rebound chamber / liners.	Improper setting of control cage.	Abrasive is being misdirected into internal components instead of work area. Check blast pattern and readjust.
Abrasive leakage.	Improper sealing. Improper control cage setting.	Check all seals for wear. Abrasive rebounding from side of machine. Check blast pattern.
Machine will not drive.	Drive pin not installed Speed control potentiometer worn, drive board faulty. Forward or Rev switch faulty, limit switch faulty, 120V missing. Drive pin not installed.	Install drive pin. Vary speed control to change speeds. Replace potentiometer, drive board or other faulty component if necessary.
Machine hang-up.	Uneven work surface / floor obstruction.	Push down on steering handle to raise machine to clear small obstructions or uneven work surfaces. Shut abrasive valve if obstruction can be cleared. Reverse direction to clear. <u>Use caution when raising seal due to high velocity abrasive exposure.</u>
Loss of cleaning action.	Machine travel speed too fast.	Adjust travel speed potentiometer.

Troubleshooting

10.2 Ventilation System (6-54 Dust Collector)

Note: Once the 654 Ultra-Jet Dust Collector has been in operation for several hours, a stable operating level will result. Sudden changes in operation can usually be traced to a malfunction.

Trouble	Probable Cause	Remedy
Contaminated abrasive - fines and contaminants not being removed from abrasive.	Very soft concrete removal. Excessive dust quantities entering system. (Will cause excessive component wear.) Insufficient air flow being delivered by exhaust fan.	Increase machine speed to reduce the amount of concrete removal or reduce abrasive flow to wheel. Check fan rotation, check exhaust hose and connections. Check air control gate
Visible dust discharge.	Torn, punctured or improperly installed filter cartridges.	Check filters (clean air section should show which filter is faulty). Replace or reinstall. (New machines will allow small amounts of dust through filters for about 1/2 hour until filters are broken in.)
High differential pressure.	Clogged filters. Screen clogged / dirty.	Check filter pulsing rate and pressure. Pressure should be 80 to 100 PSI and drop about 30 PSI for each pulse occurring once every 10 - 11 seconds. Do not allow dust bin to overflow. Filters old and saturated – replace filters. Clean / Replace screen located inside filter chamber.



Troubleshooting

10.2 Continued

Trouble	Probable Cause	Remedy
Pressure loss. Pressure loss (Continued).	Pressurized air leak.	Check all high pressure air connections.
	Goyen diaphragm stuck open.	Check solenoid valves operation Replace if necessary. Check diaphragm(s). Clean or replace if necessary.
	Unloader valve not holding pressure.	Adjust or replace unloader valve.
	Compressor not building air properly. Timer board malfunction.	Repair or replace compressor. Check air hoses for leaks. Check "tell-tale" lights on timer board, replace if necessary.

10.3 Vacuum Adjustment – Operating Tips

The vacuum adjustment gate on the 654 Dust Collector is used to reduce or increase the suction through the hose between the dust collector and the blast machine. Closing the vent increases the suction.

For normal concrete surfaces, Blastrac does not recommend using more than the 50 feet of exhaust hose supplied with the blast system. Adding additional hose can cause insufficient suction which will allow unwanted dust and contaminants to accumulate in the abrasive, thereby causing premature wear to the blast wheel and liners. Additional hose can only be added when cleaning steel surfaces. Contact your Blastrac representative for your specific steel cleaning application.

Normal shotblasting with the blast unit will usually be accomplished with the vacuum adjustment gate partially open. Too much suction will sometimes allow abrasive to be



Operating Instructions

**1-10D/1-10DSMKIII
& 1-15D/1-15DSMKIII**

Troubleshooting

10.3 Continued

pulled from the blast unit and deposited into the dustpan. This is particularly true when using small sizes of abrasive such as S - 170 and S - 230.

When using the 654 Dust Collector with the 1-15DMKIII or 1-15DSMKIII, the vacuum adjustment gate should be fully closed for maximum suction. The 1-15DMKIII and 1-15DSMKIII cleans a wider area and generates more dust, which necessitates the maximum possible suction.

A period of trial and error may be necessary for specific job applications. Generally speaking, the more dust generated by your shotblasting unit, the greater the suction you will need from the dust collector to keep the abrasive as clean as possible.



Operating Instructions

**1-10D/1-10DSMKIII
& 1-15D/1-15DSMKIII**

Electrical Troubleshooting

Section 11

11.1 General

11.2 Dust Collector

11.3 Blast Unit

11.1 Electrical Troubleshooting

Note: All operators and maintenance personnel should read and understand the entire Operating Instructions Manual before attempting to operate or maintain this machine. Pay close attention to all safety instructions, dangers, warnings and cautions.

The following icon is used in this section: Equals a Troubleshooting suggestion.

BEFORE BEGINNING TROUBLESHOOTING OR MAINTENANCE WORK ON THIS EQUIPMENT:

1. All power sources (Electrical, Pneumatic, Mechanical) of energy must be locked off, tied off or otherwise neutralized to be considered harmless.
2. It is important that operators and maintenance personnel receive regular equipment safety training,
3. AND have a thorough working knowledge of all electrical, pneumatic and mechanical aspects of this equipment and observe all warnings and precautions.

No machine function will operate.

WARNING: Only qualified personnel should perform maintenance or troubleshoot this equipment.

- Check main power. Voltage must be within parameters set out in Section 4, "Startup Procedure", and Item 8.
- Assure main disconnects in dust collector and/or blast unit control panels are "on".
- Check Phase Sequence/Voltage Monitor PM1 L.E.D. Display. If the display shows other than steady green, improper phase rotation is being presented to the system or a phase is missing.
- Assure Voltage Select Switch is in proper position according to Voltmeter indication.
- Check Transformer Primary Protection (CPOL). If tripped, use caution. **The opening of a branch-circuit device may be an indication that a FAULT CURRENT has been interrupted. To ensure continued protection against fire or electric shock, current carrying parts and other components of the**

Electrical Troubleshooting

11.1 Continued

combination controller should be examined and replaced if damaged. If burnout of the current-element of an overload relay occurs, the complete overload relay must be replaced. **ONLY THEN** reset by turning “off” then back “on”. Refer to (Dust Collector and Blast Unit) Electrical Schematics, Sheet 2 of 3, for locations of overload devices in control panel.

- ☑ Check CB1 (Control Transformer Secondary Protection). If tripped, check for a fault. If clear, reset by turning “off”, then back “on”. Assure green “Control Power” pilot light is on indicating control power is available.
- ☑ Check status of Emergency Stop switch on panel. If off, assure that no emergency state exists, then reset the switch by pulling to release and reset to a “run” mode.

11.2 Dust Collector

Blower won't come on.

- ☑ Lock out power supply at the source (generator, disconnect switch, distribution panel, etc.), open panel door and check 2MLV AND 2MHV overloads in the control panel. If tripped, use caution. **The opening of a branch-circuit device may be an indication that a FAULT CURRENT has been interrupted. To ensure continued protection against fire or electric shock, current carrying parts and other components of the combination controller should be examined and replaced if damaged. If burnout of the current-element of an overload relay occurs, the complete overload relay must be replaced. ONLY THEN,** reset by turning “off”, then back “on”. Check overload for proper setting according to the schematic. If problem persists, check motor for excessive current.
- ☑ Assure multi-pin connector on the left side of the dust collector is properly connected and mechanically secured.

Compressor won't come on.

- ☑ Lock out power supply at the source (generator, disconnect switch, distribution panel, etc.), open panel door and check 1MLV AND 1MHV overloads in the control panel. If tripped, use caution. **The opening of a branch-circuit device may be an indication that a FAULT CURRENT has been interrupted. To ensure continued protection against fire or electric shock, current carrying**

11.2 Continued

parts and other components of the combination controller should be examined and replaced if damaged. If burnout of the current-element of an overload relay occurs, the complete overload relay must be replaced. **ONLY THEN**, reset by turning “off”, then back “on”. Check overload for proper setting according to the schematic. If problem persists, check motor for excessive current.

Pulse Board won't operate.

- Fan not running. Fan must be running before power is presented to Pulse Board.
- Check glass fuse on Pulse Board. If blown, check solenoid coils. If bad coil, clean valve and replace solenoid coil. Replace fuse on Pulse Board with **EXACT** replacement.

11.3 Blast Unit

Blast Wheel will not operate.

- Lock out power supply at the source (generator, disconnect switch, distribution panel, etc.),** open panel door and check 1MLV AND 1MHV overloads in the control panel. If tripped, use caution. **The opening of the branch-circuit protective device or a similar protective device downstream may be an indication that a FAULT CURRENT has been interrupted. To ensure continued protection against fire or electric shock, current carrying parts and other components of the combination controller should be examined and replaced if damaged. If burnout of the current-element of an overload relay occurs, the complete overload relay must be replaced. ONLY THEN** reset by turning “off”, then “on”. Check overload for proper setting according to the schematic. If problem persists check motor for excessive current.

DC Gearmotor will not run.

- Drive not responding to speed pot. Assure that speed pot knob is secure to pot shaft.
- Assure connectors between control panel and DC Gearmotor are connected and mechanically secure.
- Assure connectors in handle mounted control unit are securely latched.



Operating Instructions

**1-10D/1-10DSMKIII
& 1-15D/1-15DSMKIII**

Electrical Troubleshooting

11.3 Cont'd

- Lock out power supply at the source (generator, disconnect switch, distribution panel, etc.),** open panel door and check fuse on DC Drive in control panel.
- Check drive chain for binds.



Operating Instructions

**1-10D/1-10DSMKIII
& 1-15D/1-15DSMKIII**

Specifications

Section 12

- 12.1 Specifications – Dust Collector
- 12.2 Specifications – Blast Unit
- 12.3 Site and Equipment Electrical Requirements



Specifications

12.1 Specifications – Dust Collector

Table 1: 6-54 MECHANICAL DATA	
Length	4 feet 4 inches
Width	2 feet 9 inches
Height	5 feet 3 inches
Weight	850 pounds
Filter Cartridges	6 (6 inches - diameter; 16 inches in length)
Total Filter Area	324 square feet
Air Flow	540 CFM

Table 2: 6-54 MOTOR DATA				
Motor	Horsepower	FLA @ 208	FLA @ 230	FLA @480
Compressor	3/4 HP	2.4	2.4	1.2
Blower	5.0 HP	13.2	12	6

12.2 Specifications – Blast Unit

Table 3: 1-10DMKIII - MECHANICAL DATA	
Length	5 feet 7 inches
Width	1 foot 5 inches
Height	3 feet 3 inches
Weight	825 pounds
Wheel	8 inches
Cleaning Width	10 inches
Bearing Unit: Operating RPM Grease	6800 RPM Mobilux 77 EP-2 or Mobilelith AW-2 or equivalent



Operating Instructions

**1-10D/1-10DSMKIII
& 1-15D/1-15DSMKIII**

Specifications

12.2 Continued

Table 4: 1-10DSMKIII - MECHANICAL DATA

Length	5 feet 3 inches
Width	1 foot 5 inches
Height	3 feet 4 inches
Weight	855 pounds
Wheel	8 inches
Cleaning Width	10 inches
Bearing Unit: Operating RPM Grease	6800 RPM Mobilux 77 EP-2 or Mobilelith AW-2 or equivalent

Table 5: 1-15DMKIII - MECHANICAL DATA

Length	6 feet 7 inches
Width	1 foot 11 inches
Height	3 feet 6 inches
Height	3 feet 6 inches
Weight	802 pounds
Wheel	8 inches
Cleaning Width	15 inches
Bearing Unit: Operating RPM Grease	6700 RPM Mobilux 77 EP-2 or Mobilelith AW-2 or equivalent

Table 6: 1-15DSMKIII - MECHANICAL DATA

Length	6 feet 7 inches
Width	1 foot 11 inches
Height	3 feet 6 inches
Weight	820 pounds
Wheel	8 inches
Cleaning Width	15 inches
Bearing Unit: Operating RPM Grease	6700 RPM Mobilux 77 EP-2 or Mobilelith AW-2 or equivalent



Operating Instructions

**1-10D/1-10DSMKIII
& 1-15D/1-15DSMKIII**

Specifications

12.2 Continued

Table 7: Blast Unit Motor Data				
Motor	Horsepower	FLA @ 208	FLA @ 230	FLA @480
DC Gearmotor	1/4 HP	3.5*	3.5*	3.5*
1-10DMKIII Blast	10.0 HP	28.5	25.8	12.9
1-10DSMKIII Blast	15.0 HP	37.6	34.0	17.0
1-15DMKIII Blast	15.0 HP	37.6	34.0	17.0
1-15DSMKIII Blast	20.0 HP	55.3	50.0	24.0

*The DC Gearmotor Drive Is 120v. It derives power from the control power transformer.

12.3 Site and Equipment Electrical Requirements

**Site and Equipment Electrical Requirements for
Dust Collector/Blast Unit Combinations**

Table 8: Site Power Requirements and Blast Motor Maximum Blast Amps				
Parameter	Dust Collector/Blast Unit Combinations			
	6-54/ 1-10DMKIII	6-54/ 1-10DSMKIII	6-54/ 1-15DMKIII	6-54/ 1-15DSMKIII
Minimum Ampere Circuit @ 208/230V	50 AMP	60 AMP	60 AMP	80 AMP
Maximum Ampere Circuit @ 208/230V	100 AMP	100 AMP	100 AMP	100 AMP
Minimum Ampere Circuit @ 460/480V	30 AMP	40 AMP	40 AMP	50 AMP
Maximum Ampere Circuit @ 460/480V	100 AMP	100 AMP	100 AMP	100 AMP
Minimum Generator Size	30 kW	40 kW	40 kW	60 kW
Maximum Blast FLA @ 208/230	25.0 AMP	33.0 AMP	33.0 AMP	49.0 AMP
Maximum Blast FLA @ 460/480	12.5 AMP	16.5 AMP	16.5 AMP	22.5 AMP



Operating Instructions

**1-10D/1-10DSMKIII
& 1-15D/1-15DSMKIII**

Electrical Conversion

Section 13

13.1 Electrical Conversion

Electrical Conversion

13.1 Electrical Conversion

Note: This section is only applicable to dual voltage units and does not apply to single voltage machines.

The control systems for the 6-54 Dust Collector and family of blast units including the 1-10DMKIII, 1-10DSMKIII, 1-15DMKIII and 1-15DSMKIII were designed to safely operate in the range of 3 phase, 60 Hertz voltages typically available in the United States (208, 230, 460 and 480).

All of these control systems feature "Auto Voltage Sensing" (AVS) circuitry. AVS was developed to protect the equipment and operating personnel and to simplify this electrical conversion process. While some differences certainly exist in the power components of the dust collector and each of the blast units, the electrical conversion procedure is identical for all.

BRIEF OVERVIEW:

1. Turn Main Disconnect switch to the "on" position.
2. Set the Emergency Stop switch to the "on" position.
3. Observe the "Proper Rotation" and "Improper Rotation" pilot lights. If "Improper Rotation" lights, the power leads must be switched or one of the phases is dead. **REMEMBER to turn off power when going into a panel.** If the "Proper Rotation" pilot light is on, continue.
4. Set the "Voltage Select" switch to the voltage range indicated by the voltmeter.
5. When the "Control Power" light comes on, the machine is ready to operate.

RECOMMENDED PRACTICE:

It is good practice to check the voltage source prior to presenting power to the equipment. Use a reliable voltmeter for this check. The equipment will operate normally on a $\pm 10\%$ of the low or high voltage range.

For example:

- Low Voltage - If the supply voltage is a nominal 208 to 240 volt, the measured voltage should not be less than 187 volts nor more than 264 volts.



Operating Instructions

1-10D/1-10DSMKIII
& 1-15D/1-15DSMKIII

Electrical Conversion

13.1 Continued

- High Voltage - If the supply voltage is a nominal 460 to 480 volt, the measured voltage should not be less than 414 volts nor more than 528 volts.

If the measured voltage falls outside these parameters, it must be corrected before proceeding.

When one of these thresholds has been verified, continue this process.

1. Turn the main disconnect on the dust collector or blast unit switch to the “On” position.
2. Set the Emergency Stop switch by pulling it until it is latched in the “Out” position.

This will allow the control system to begin an initiation/measurement sequence to determine phase sequence and measure the incoming voltage.

Before the AVS circuit will allow operation, it must verify four parameters.

- First, all three phases must be present.
- Second, the phase rotation, consequently motor rotation, must be correct.
- Third, the voltage presented to the equipment must be within certain thresholds.
- And fourth, the voltage selector switch must be in the proper position.

Until all four are satisfied, this equipment will not operate.

NOTE: These units are factory tested to verify rotation. While this equipment contains a phase monitoring device that will help assure proper rotation of the motors, a quick rotation check should always be made prior to startup of the equipment. The effectiveness of the phase monitor assumes it, nor the wiring in the panel, has not been tampered with. If maintenance involving the wiring has been performed, the rotation of both the dust collector and the blast unit **must be verified**. If proper rotation is observed, it will remain so.



Electrical Conversion

13.1 Continued

3. Observe the pilot lights indicating “Proper Rotation” (Green) and “Improper Rotation” (Red).
 - If the red “Improper Rotation” comes on, two conditions may exist.
 - a. A “single-phase” condition may exist. Measure voltage from each phase to ground. Identify the missing leg and repair.
 - b. Phase rotation is improper. In this event, two of the three power wires, black, red or white (not green) connected to site power must be reversed to correct the phase sequence (rotation). **Disconnect power before reversing the leads.**
 - If the green “Proper Rotation” light is on, the operator may proceed.
4. Set the ‘Voltage Select’ switch to the proper position. Check the digital voltage readout located on the dust collector or blast unit control panel.
 - If the indication is between 187 and 264 volts, set the “Voltage Select” switch to “Low Volts”.
 - If the indication is between 414 and 528 volts, set the “Voltage Select” switch to “High Volts”.
5. If the setup is correct, the “Control Power” light (green) will illuminate. These lights indicate that control power is present, the machine is properly connected electrically, and ready to be started.



Operating Instructions

**1-10D/1-10DSMKIII
& 1-15D/1-15DSMKIII**

Spare Parts

Section 14

14.1 Spare Parts 1-10D/1-10DSMKIII & 1-15D/1-15DSMKIII

Spare Parts

14.1 Spare parts

Blast wheel unit

Item	1-10D Part No.	1-15D Part No.	Description	Qty.
	B21620		Bearing unit with flange (Item 1-4)	1
1	B21629	4892950	Bearing unit	1
2	B21624	4959430	Bearing unit flange	1
3	B20295	4959380	Felt seal	1
4	B21625	4959370	Felt seal cover	1
5	B21075	N/A	Distance ring for tune-up kit (set of 2)	10
6	B20397	4959400	Wheel hub	1
7	9796440	6762610	Blast wheel cover plate	1
8	6940730	4146990	Control cage clamp	2
9	P002820	6856360	Wheel kit	1

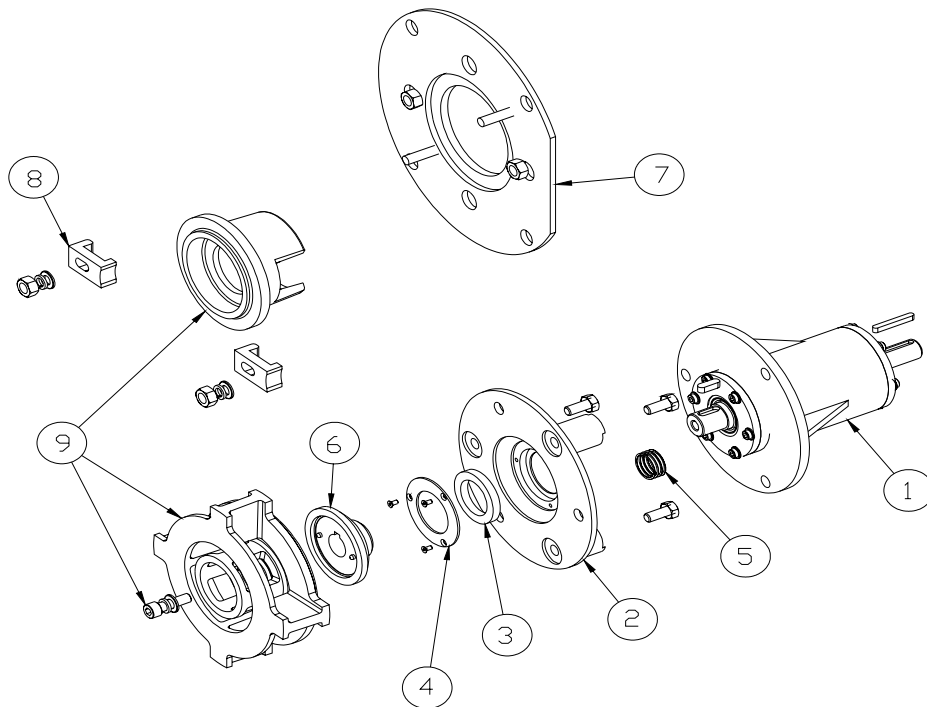

Fig. 10.1

Spare Parts

Liners

Item	1-10 Part No.	1-15 Part No.	Description	Qty.
1	B20325	4990910	Top liner	1
2	B20398	4899470	Left liner	1
3	B20399	4899480	Right liner	1
4	9722750	4900450	Plenum side liner	2
5	4900440	4990930	Plenum top liner	1
6	9695720	4990920	Plenum bottom liner	1
7	9695790	N/A	Liner screw M10 x 35 (used on 1-10 only, the screw on the 1-15 is integrated in the liner)	2

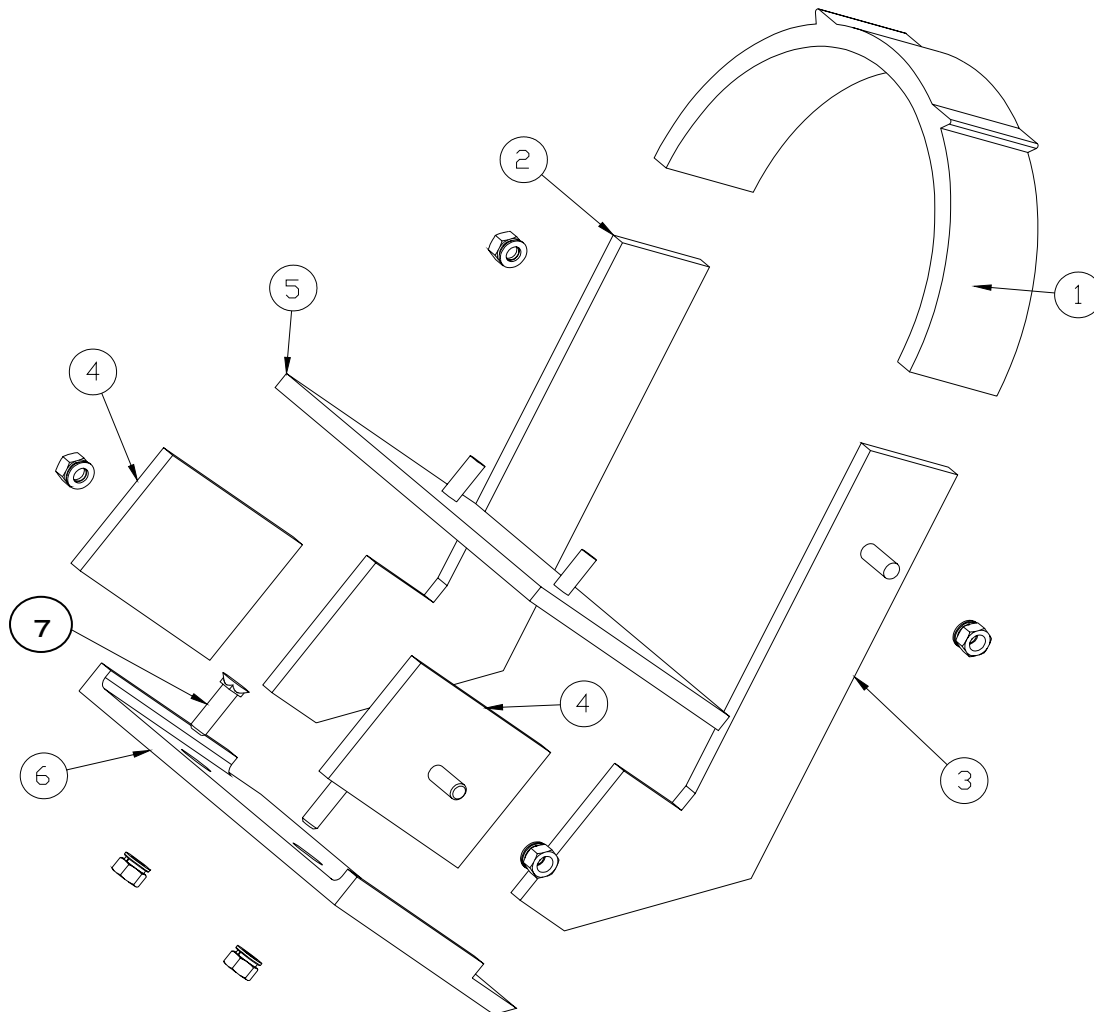

Fig. 10.2



Operating Instructions

1-10D/1-10DSMKIII
& 1-15D/1-15DSMKIII

Spare Parts

Traction drive – 1-10D

Item	Part no.	Description	Qty.
1	9801600	Drive wheel bracket	1
2	9701980	Lifting fork	1
3	E00967	Steering lever	1
4	970132-1	Drive motor bracket	1
5	4835160	Drive motor	1
6	9801140	Traction wheel yokeshaft	1
7	4900790	Traction wheel	1
8	9753460	Drive shaft	1
9	2055710	Bearing ¾"	2
10	4776290	Drive wheel hub	1
11	4776300	Sprocket retainer	1
12	4776310	Idler sprocket	1
13	9710430	Sprocket ½"	1
14	2546610	Drive chain, #40	37"
15	4528360	Chain link	1
16	4781980	Quick release pin	1
17	E00965	Chain guard	1
18	E00966	Chain guard cover	1
19	P000168	Limit switch	1
20	4900740	Traction drive switch lever	1
21	4532900	Handle grip	1
22	9702470	Bracket pin	1
23	B20316	Bearing shaft	2
24	B20327	Bearing	2
25	2621-671	Sleeve-bearing bush	1

Spare Parts

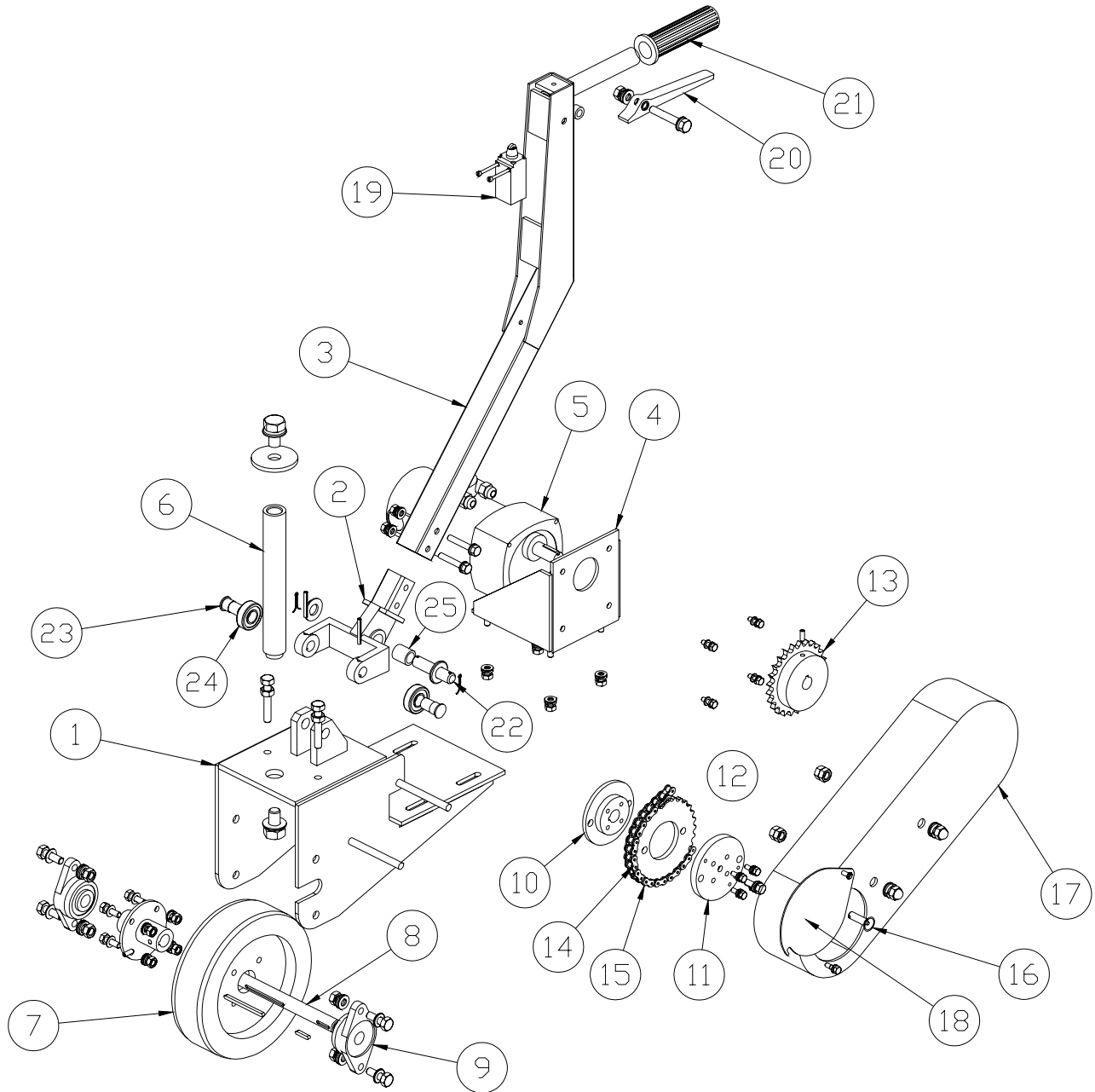

Fig. 10.3a



Operating Instructions

1-10D/1-10DSMKIII
& 1-15D/1-15DSMKIII

Spare Parts

Traction drive – 1-15D

ITEM	PART NUMBER	DESCRIPTION	QUANTITY
1	205571	BRG/FG 2 DODGE BALL SC	2
2	490079	WHEEL/POLY 6"	1
3	490072	SHAFT/TRACTION DRIVE	1
4	491968	PIN/CLEVIS 5/8" x 1.75" LG.	2
5	491948	LINKAGE	1
6	490078	YOKE/TRACTION DRIVE	1
7	84234	SPROCKET / 40-1A 26T	1
8	477629	HUB/DRIVE SPROCKET	1
9	477631	SPROCKET/TRACTION DRIVE	1
10	477630	RETAINER/SPROCKET	1
11	452836	LINK/CONNECTING MASTER ASA #40 0.50" P	1
12	478198	PIN/QUICK RELEASE - RECESSED 3/8" DIA.	1
13	254661	CHAIN/ROLLER ASA #40 - 0.50" PITCH	1
14	490077	GUARD/TRACTION DRIVE	1
15	P000589	COVER/OPERATOR CONTROL MOUNTING BRACKET	1
16	453290	GRIP/HANDLE 1.00" I.D. RUBBER	1
17	490074	LEVER/SWITCH - TRACTION DRIVE	1
18	490076	HANDLE/ASSY	1
19	P000588	BRACKET/MOUNTING - OPERATOR CONTROL	1
20	676038	PLENUM / REBOUND SLL	1
21	500209	SCREW/CAP HEX. 3/8"-16 x 5.00"	2
22	491949	LINK/ARM	2
23	491950	YOKE	1
24	500115	WASHER/LOCK 3/8"	2
25	500060	NUT/HEX 3/8"-16UNC	5
26	491969	PIN/CLEVIS x 6.00"	1
27	483516	GEAR MTR / RT ANGLE BODINE	1

Spare Parts

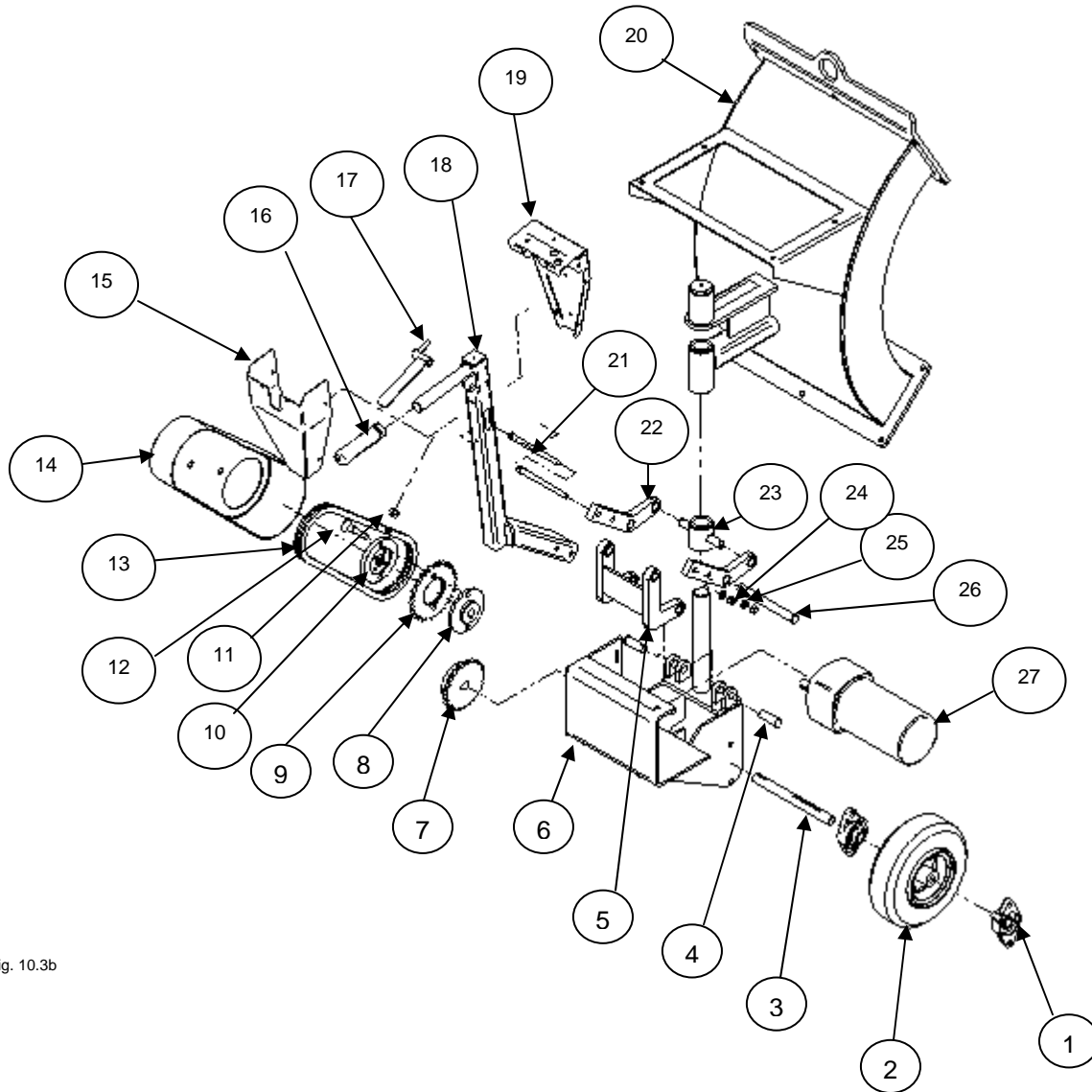

Fig. 10.3b

Spare Parts

Separator

Item	1-10 Part No.	1-15 Part No.	Description	Qty.
1	B20537	6762370	Separator	1
2	9800120	9800120	Deflector	1
3	9701170	6762770	Separator tray	1
4	9704520	N/A	Separator tray lock	1
5	9703850	Part of 6762540	Separator handle	1
6	9800110	6762540	Separator cover	1

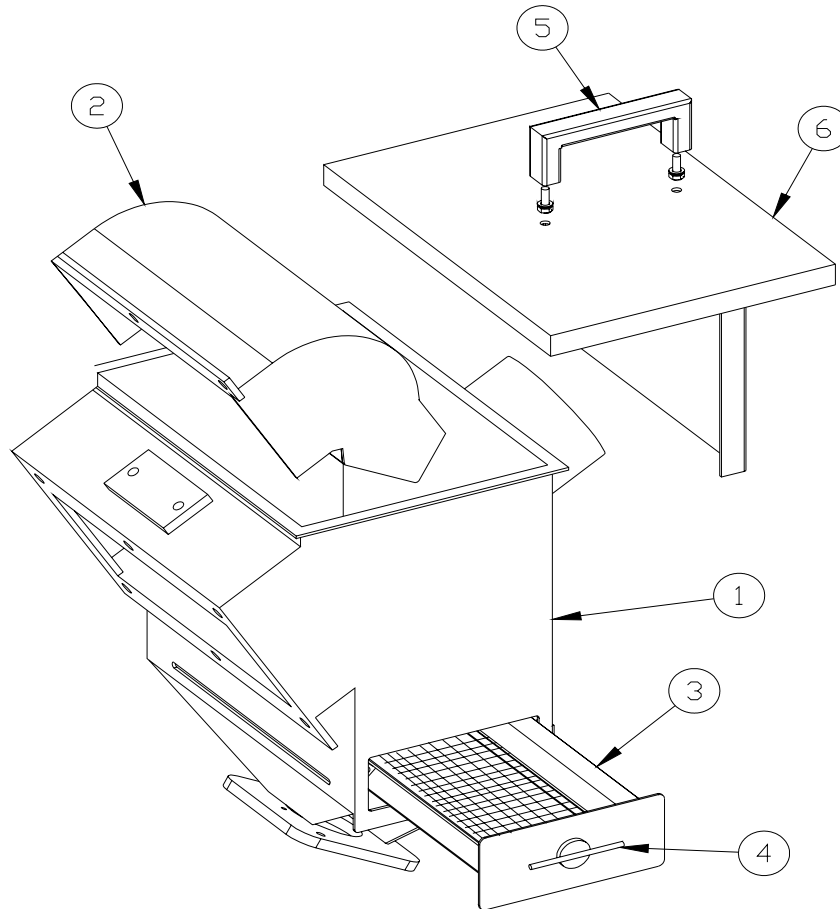

Fig. 10.4

Note: Item 4 shown here does not slide out on the 1-15. The 1-15 tray is lifted from the top.

Spare Parts

Blast housing

Item	1-10 Part No.	1-15 Part No.	Description	Qty.
1	975357-1	6761700	Blast housing	1
2	9796440	6762610	Blast wheel cover plate </td <td>1</td>	1
3	6940730	4146990	Control cage clamp	2
4	B20453	N/A	Blast housing cover seal	1
5	B20433	4990880	Blast housing cover	1
6	E00968	4899450	Insulator Side	2
7	E00969	4990900	Insulator Front	1

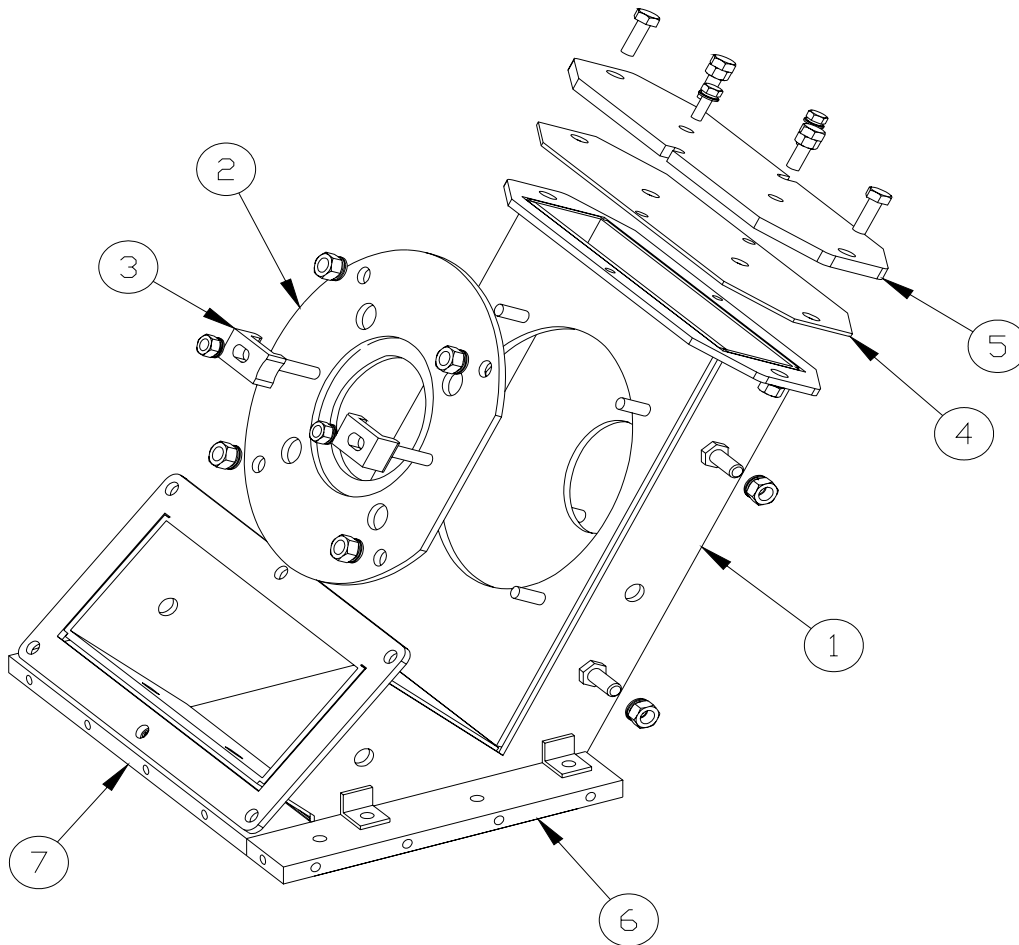

Fig. 10.5

Spare Parts

Magnetic valve unit

Item	1-10 Part No.	1-15 Part No.	Description	Qty.
1	B20443	4937000	Feed spout	1
2	B20444	6800200	Magnetic valve assembly	1
3	B20446	P000019	Valve lever	1
4	B20519	P000735	Abrasive control lever	1
5	B20520	P000737	Abrasive control cable	1
6	B20521	4917260	Pivot for abrasive control cable	1

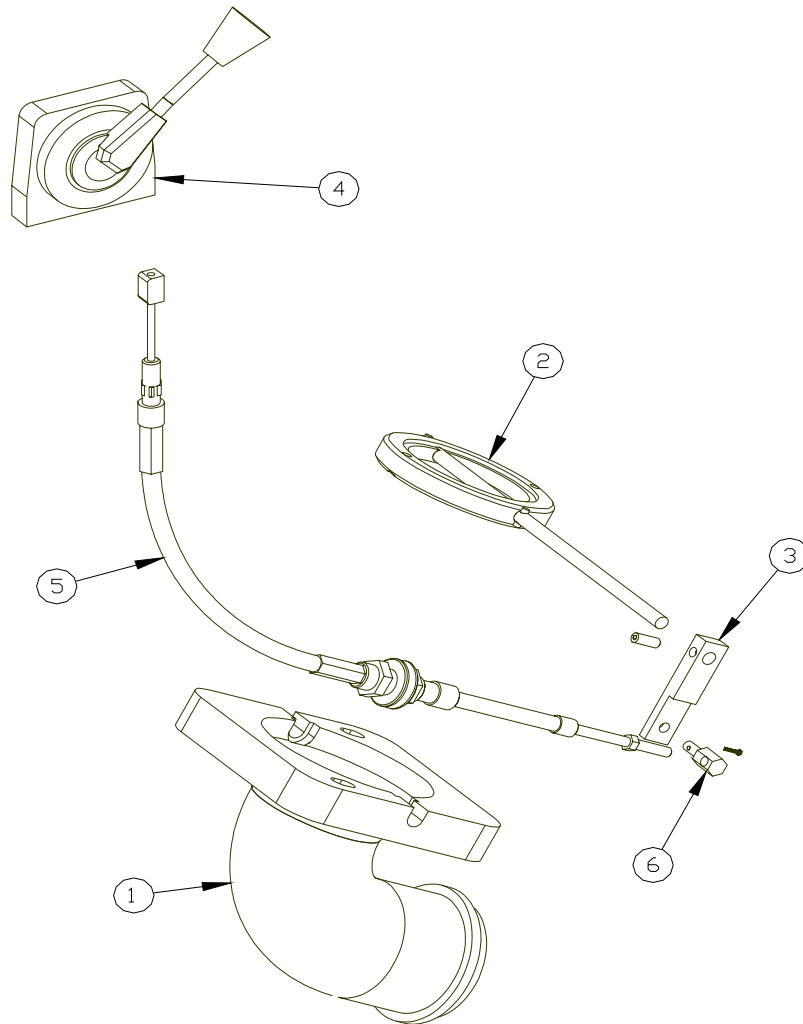

Fig. 10.6

Spare Parts

Blast head

Item	1-10 Part No.	1-15 Part No.	Description	Qty.
1	9700300	4990970	Front magnet	1
2	4900470	4899450	Side magnet	2
3	B20410	N/A	Front brush (used on 1-10 only)	1
4	B20411	N/A	Side brush right (used on 1-10 only)	1
5	B20423	N/A	Side brush left (used on 1-10 only)	1
6	6796740	6826520	Skid seal	1

Alternative for brush sealing:

7	9701900	6984390	Base seal	1
8	9700460	4991010	Seal retainer (front)	1
9	9700450	4900510	Seal retainer (side)	2

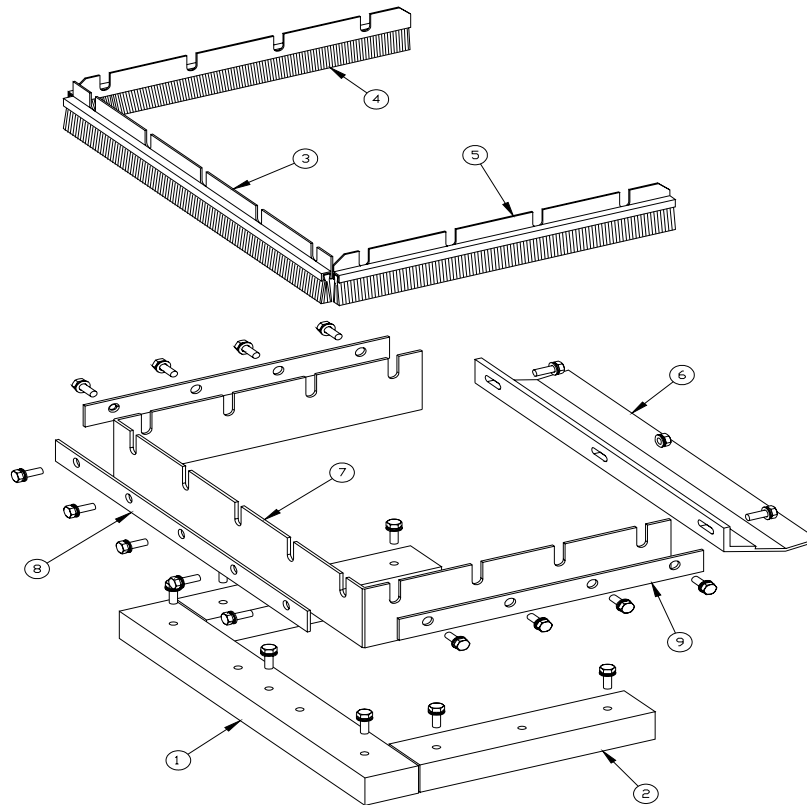

Fig. 10.7



Operating Instructions

1-10D/1-10DSMKIII
& 1-15D/1-15DSMKIII

Spare Parts

Blast wheel drive

Item	1-10 Part No.	1-15 Part No.	Description	Qty.
1	9701680	6997030	Belt guard	1
2	4932650	6997040	Sheave/Poly-V, (4.50PD w/ bushing 1-10) (6.50PD w/bushing 1-15)	1
3	P002822	6997050	Sheave/Poly-V, (2.50PD w/ bushing 1-10) (3.65PD w/bushing 1-15)	1
4	4932630	6997060	Blast motor belt	1
5	980008-1	6769980	Motor bracket	1
6	9701710	P000695	Keep plate	2
7	4915870	N/A	Blast motor – 1-10DMKIII	1
7	6976380	N/A	Blast motor - 1-10DSMKIII	1
7	N/A	6976390	Blast motor - 1-15DSMKIII	
8	B21629	4892950	Bearing unit	1
9	9701990	6762470	Idler wheel bracket	2
10	9702580	5017290	Idler axle pin	2
11	0012280	6785870	Idler wheel	2
12	9702560	5017290	Idler pivot pin	2
13	P000832	4920190	Cable Management	1
14	B21322	N/A	Eccenter Sleeve	1
15	B21324	N/A	Eccenter Socket Head Bolt	1

Spare Parts

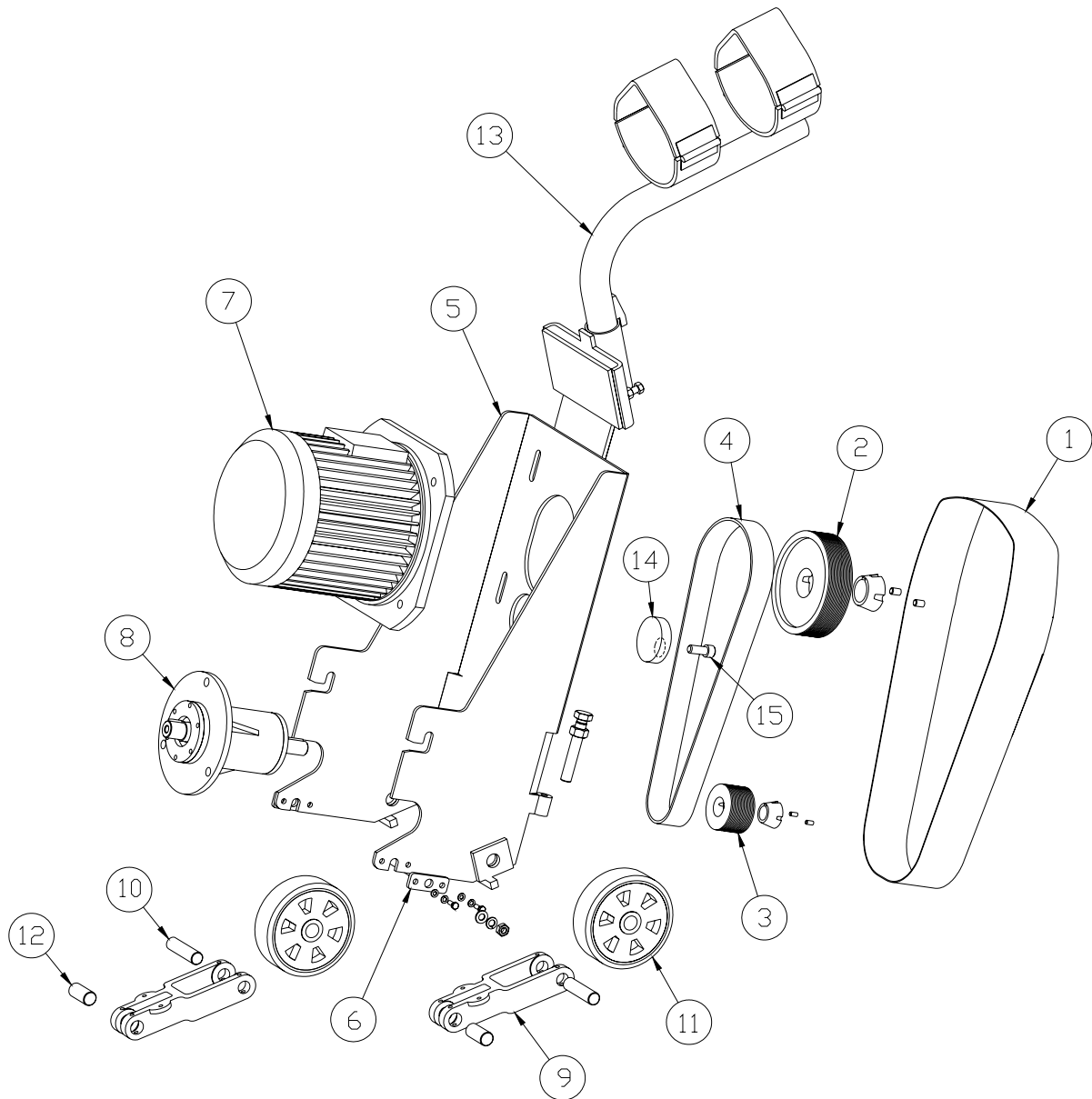

Fig. 10.8

Spare Parts

Rebound plenum

Item	1-10 Part No.	1-15 Part No.	Description	Qty.
1	9800090	6760380	Rebound plenum	1
2	B20319	See note	Shaft cover	1
3	2621-229	See note	Sleeve-bearing bush	2
4	B20315	See note	Lifting plate	1
5	B20318	See note	Seal retainer	1
6	960855-2	See note	Felt seal	1
7	4565500	4565500	Electrical Panel Isolator	4

Note: Items 2 through 6 are shown in Figure 10.3b. The setup is different on the 1-10 than the 1-15.

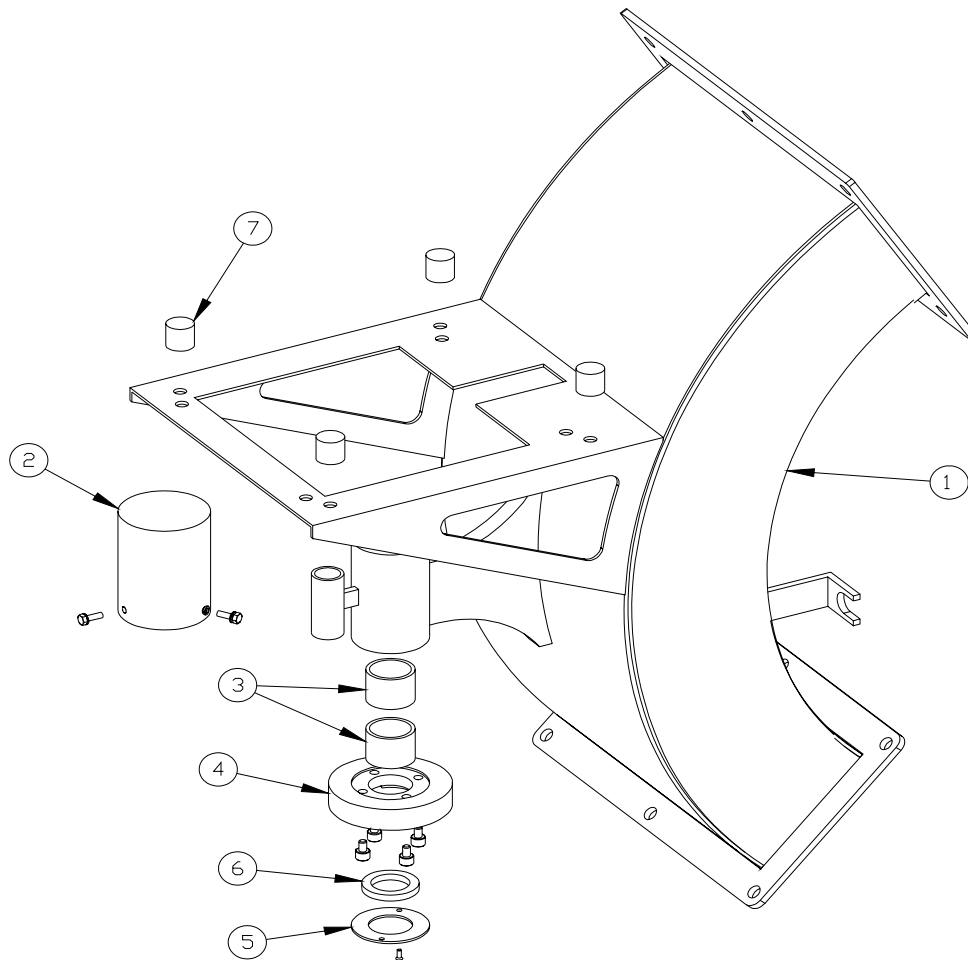

Fig. 10.9